

Sherlock Jones
and the
Odyssey Mystery

A novel
by Ed Dunlop

Book Six in the Sherlock Jones Detective Series

The *Endeavor II*

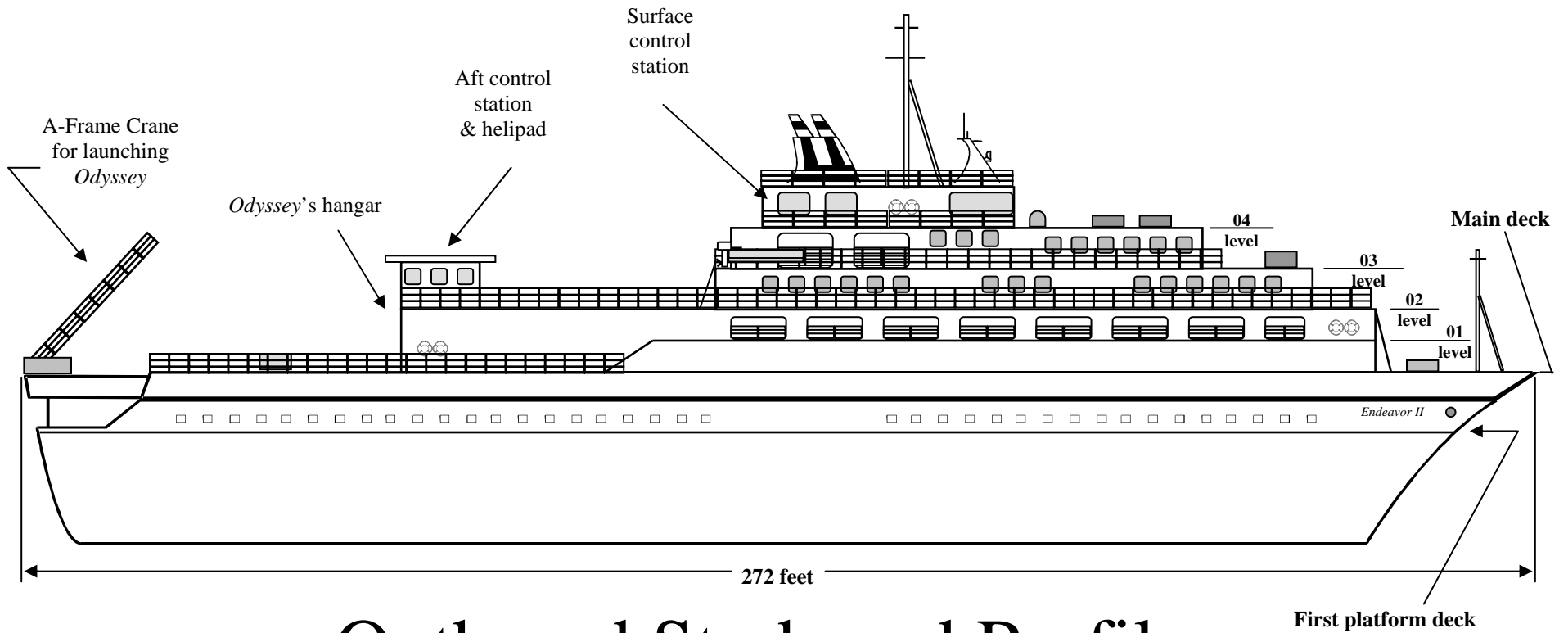

Outboard Starboard Profile

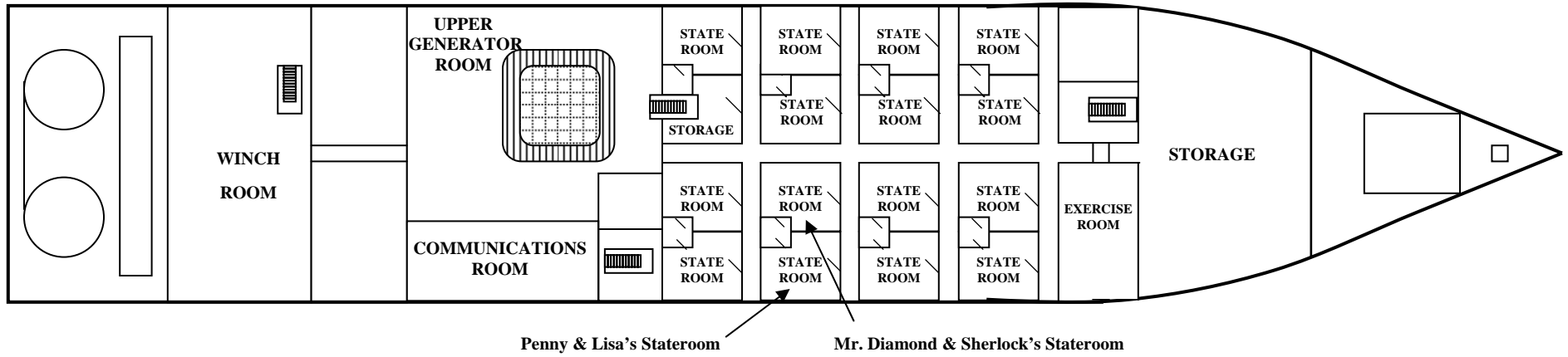

First Platform Deck

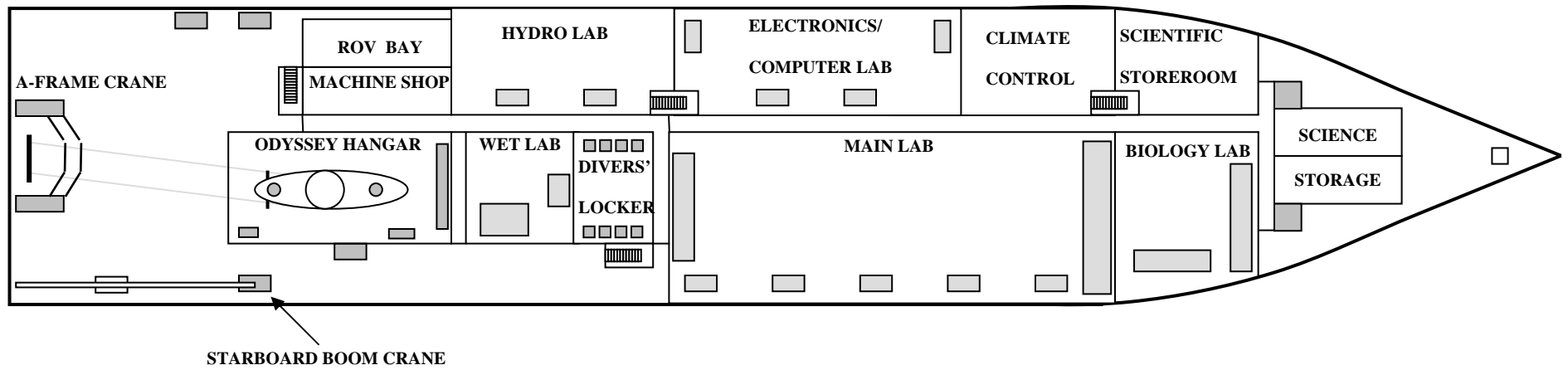

Main Deck

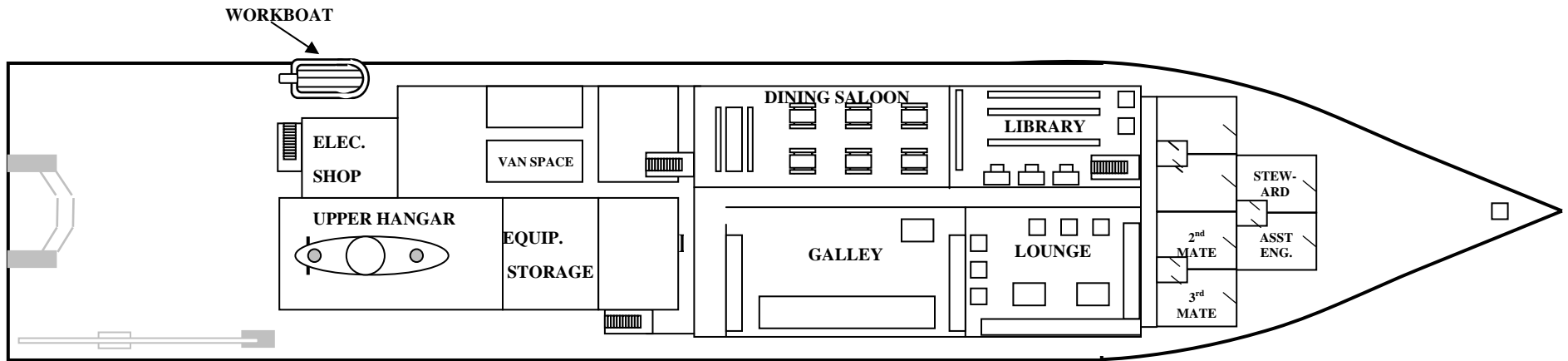

01 Level

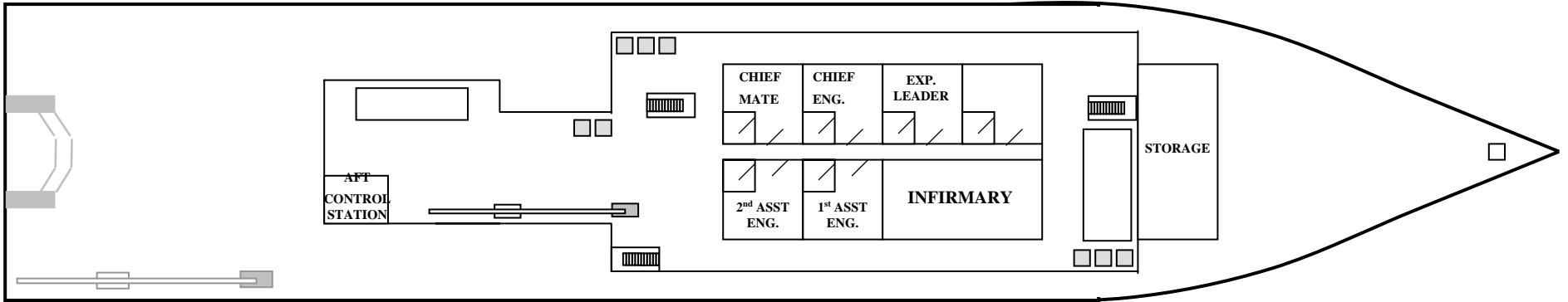

02 Level

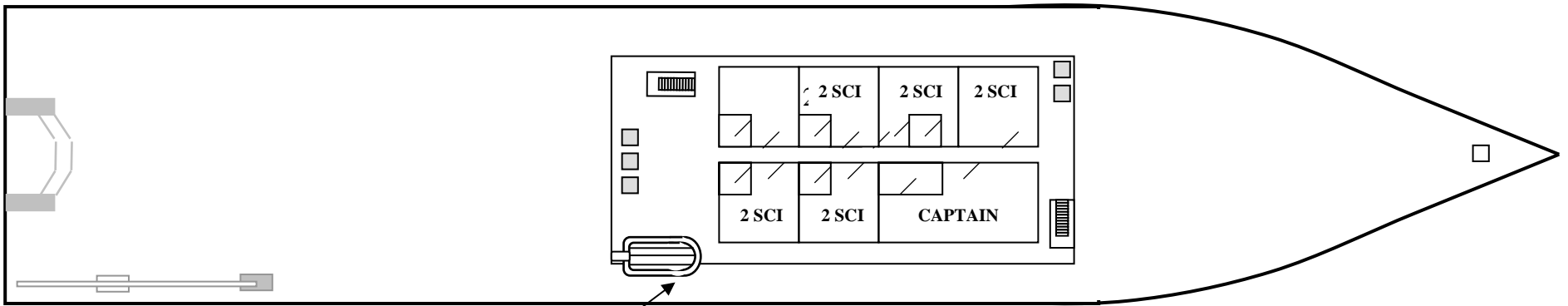

WORKBOAT

03 Level

©2001 Ed Dunlop

Chapter 1 – The Accident

“Mom! Look out!”

Mom and I were cruising through downtown Willoughby when it happened. We had just passed the bank and were entering the intersection of Main and Walnut. The light had turned green several seconds before, so Mom didn't even slow down. At that moment, though, a flashy red sports car seemed to appear out of nowhere and shot across in front of us. Mom slammed on the brakes, but it was too late.

Tires screeched. My whole world seemed to explode as our car slammed into the side of the other vehicle. There was a terrible crunching, grinding, crumpling impact, followed by an explosion that sounded like a shotgun blast. I was thrown hard against my seat belt. Our car spun around, hurled sideways by

the force of the collision. I felt myself being thrown sharply to the left, then slung to the right, and I banged my head against the window.

In less than a second and a half, it was all over. The car sat motionless, and all was quiet. I had just survived my first automobile accident.

“Penny?” It was Mom's voice, quiet, subdued, and fearful. “Penny, are you all right?”

My head was starting to hurt from cracking against the window, but other than that, I thought I was all in one piece. I took a deep breath. “I think I'm OK, Mom.”

I twisted around sideways in my seat so that I could take a good look at her. A deflated airbag hung limply from the middle of the steering wheel. Mom looked pale, and she was trembling a little, but I couldn't see any blood. “Are you OK, Mom?”

Mom nodded, and then burst into tears. “Oh, Penny. Are you sure you're all right?”

“I'm fine, Mom. Really, I am.” I patted her arm. “I just got a little bump on the head, but I'm OK.”

We both turned to stare through the shattered windshield. The other vehicle sat just a few feet from our front bumper. Mom had broadsided the car, a late model Jaguar, demolishing the door and fender on the passenger side. My heart sank.

“Mrs. Gordon, are you all right?” Mom’s door suddenly swung open, and there stood Tal Larson, a man from our church, bending down and peering into the car with a look of concern on his rugged features. “Penny, are you hurt?”

Mom let out a long sigh. “I think we’re both all right, Brother Larson.” She unsnapped her seat belt and let it slowly retract into its holder. “How about the people in the other car?”

“We’re checking,” Mr. Larson replied. “I’ll call the police for you.” He hurried away.

Just then, my own door popped open, and I turned, startled, to see the concerned face of one of my classmates, Sherlock Jones. “Penny! Are you OK?” A look of dismay swept across his thin features. “You’re hurt!”

I unsnapped my seat belt and leaned forward, twisting the car’s rearview mirror around. The familiar, freckle-faced

blonde stared back at me from the mirror, but she had a trickle of blood on her chin. I wiped my chin on the back of my hand and swung around to face my friend. “It’s nothing, Sherlock. I’m just a little shook up.”

He looked relieved. “I’ll go check the people in the other car.”

At that moment a slender woman in high heels and a business suit emerged from the driver’s side of the Jaguar and stepped quickly around the back of her car. She took one look at the damage to the right side of her car and then strode angrily toward Mom’s door. “What were you thinking, woman?” she screamed at Mom, and then cursed. “Look what you’ve done to my Jag!”

I’d guess that the woman was about twenty-eight or thirty, rather attractive, but with a mean, hard edge to her. She didn’t even bother to ask if we were all right; she just stood there ranting at Mom. “Look what you’ve done!” she shrilled again. She clenched her hands in anger, turned and looked at the damaged Jag again, and then strode over and kicked the rear bumper in fury. Eyes blazing with anger, she turned on

Mom again. “Of all the idiots! Woman, couldn’t you see—”
Overcome with rage, the woman began cursing again.

Sherlock appeared between the two cars. “Lady, I think you need to back off,” he told the angry woman. “This collision was your fault. You ran a red light!”

The woman spun around to face him. “Get lost, kid!”
She looked at Mom again. “I’m an attorney, and I’m not about to be set up by a bunch of small-town hicks!” She swore again. “This is going to cost you, woman!”

The Willoughby police station is just a block away from that intersection. At that moment, a blue and white patrol car pulled into the center of the intersection with its lights flashing, and Officer Clark scrambled out. He hurried over to the two wrecked vehicles. “Everyone OK?” he asked. He leaned down and peered into our car. “Any injuries?”

Mom shook her head. “We’re all right, Mr. Clark.”

Mom and I climbed from the Taurus and walked to the front to inspect the damage. My heart sank. The front end of our car was a mangled wreck. The bumper and grill had been twisted to the right with tremendous force, buckling the hood and fenders, shattering the windshield, and flattening the right

tire. We hadn’t been going that fast. Could the momentum of the Jaguar have done this much damage to our car? I was sure that the Taurus was totaled.

The woman attorney started ranting and raving again at Officer Clark about the accident being Mom’s fault, and threatening the city of Willoughby with legal action if he didn’t cite Mom for causing the accident. A crowd began to gather in the middle of the intersection as the woman continued her tirade. Just then the other Willoughby police car pulled up, and Officer Bill hopped out and started directing traffic.

Officer Clark stepped away from the obnoxious woman. Raising his voice, he asked, “Are there any witnesses? Did anyone observe the accident?” Several voices answered at one time.

“I saw it, Clark!”

“I did!”

“I was right on the corner, waiting to cross with the light. I saw the whole thing!”

“I’m telling you,” the attorney said emphatically, “this woman ran a red light! What more do you need to know?”

Clark had had about enough. “Quiet, ma’am,” he ordered. “I’ll get your statement in a minute. Right now, I need to identify some witnesses and get their accounts.” He turned to Mr. Larson. “What happened, Tal?”

Mr. Larson held up both hands. “Sorry, Officer Clark, but I didn’t see it. I’m afraid I can’t be much help.”

Clark turned to an older man who I didn’t know. “Did you see it?”

The man nodded. “That fancy red car there ran against a red light. The white Ford just plowed right into it. Ka-pow!”

“Now, hold on!” the attorney sputtered. “That’s not the—”

Clark held up one hand to cut her off. “You’ll have your say in a moment.”

Mrs. Smedley stepped forward. “I saw the whole thing, Mr. Clark. Mrs. Gordon there entered the intersection two or three seconds after the light changed. The Jaguar came through on the green and was broadsided.”

“Just a minute, sir,” a man insisted, “that’s not the way it was. The Jaguar was in the middle of the intersection, making a left turn, when the Taurus pulled out from a parking

meter.” I don’t think it occurred to the man that there are no parking meters on Main Street.

Another voice spoke up. “Wait. There was a truck involved—a yellow rental truck. It was...”

“They’re all wrong, Clark. The Jag was turning right, and—”

I groaned. This was as bad as the time that the Willoughby bank was robbed. Each witness had a completely different story.

Officer Clark threw up both hands in desperation. He turned to Sherlock. “Did you see what happened? These people seem to be describing sixteen different accidents!”

Sherlock and I are both in the same seventh-grade class. He’s my best friend, even if he is a boy, and he’s an absolute genius. He’s the most observant person you’ve ever met, and he has a photographic memory, which comes in handy in his detective work. I knew that if Sherlock had witnessed the collision he would be able to give a detailed, accurate account. I held my breath, waiting for Sherlock’s answer.

To my relief, he nodded. “Yes, sir,” he replied, “I was standing in front of the bank and observed the entire incident.

The Jaguar, traveling northbound on Walnut at a speed that I would estimate to be approximately fifteen to twenty miles an hour in excess of the speed limit, entered the intersection five or six seconds after the light had turned to red. Mrs. Gordon's car was west-bound on Main Street and entered the intersection on a green light, resulting in a collision with the Jaguar."

I let out a sigh of relief. At least the accident was not Mom's fault.

"You're saying that the Jaguar ran a red light?" Clark asked.

"Yes, sir," Sherlock replied confidently.

"You're sure."

"Yes, sir, I'm positive."

Officer Clark turned to the driver of the Jaguar. "I'm afraid that your story conflicts with that of our most reliable eye-witness, ma'am." He pulled a ticket book from his pocket. "I'll have to cite you for running a red light and failing to yield the right-of-way."

The woman cursed. "Now just a minute, Officer! You're not going to get away with this!" She opened her hand and thrust a business card at him. "I'm Laura Cheatham,

senior partner in the law firm of Cheatham and Wilson. If you think you're going to nail this one on me, you had better reconsider!"

Officer Clark stood up to her. "I have a reliable eye-witness, ma'am, who says that you—"

Miss Cheatham snorted. "You're going to make your decision based on the word of a child? You're telling me, sir, that you intend to cite me for this accident based on the word of this scrawny little runt?" She spun around and pounced on Sherlock. "How old are you, kid? Nine? Ten?"

I could tell that Sherlock was frustrated, but he sighed and responded politely, "I just turned twelve, Miss Cheatham. I'm in seventh grade."

The woman was indignant. "Officer, if you think you're going to make a case against me based on the word of a twelve-year-old child, you'd better think again! When my law firm and I get through with you, you'll wish you had never gone into law enforcement."

Officer Bill stepped over. He's a tall, young, single, good-looking guy who makes my heart beat a little faster every time I see him. Best of all, he's saved and loves the Lord.

“Clark, we’d better get these people out of the street before someone gets hit.” He raised his voice. “Everyone move over on the sidewalk in front of The Electric Beach, please. Let’s clear the street.”

As the crowd of by-standers hurried over to cluster in front of the tanning salon in response to Officer Bill’s orders, Mom put her arm around me. “Sure you’re OK, Penny?”

“I’m fine, Mom,” I assured her. “Are you sure you’re OK?”

“Physically, yes, emotionally, no,” she answered. She began to sob. “Oh, Penny, what if the accident *is* my fault? Right now I’m not sure if the light was red or green. I really don’t remember. What if I did run a red light, like this woman insists that I did?”

Sherlock joined us just then. “You didn’t run a red light, Mrs. Gordon,” he asserted. “I saw the entire incident! The light had changed to green at least five or six seconds before you entered the intersection. That overbearing attorney was the one who ran the light!”

“But can we prove that?” Mom replied. “There are so many different accounts from these eye-witnesses.”

Sherlock snorted. “Most people aren’t observant, Mrs. Gordon. They don’t keep their eyes open like I do. I saw the entire thing, and I distinctly saw the light change a good five or six seconds before—”

Mom laid a hand on his shoulder. “I’m not doubting you, Sherlock. If you say that I went through on a green light, then I have no doubt at all that I did. I’m glad to find out that this collision was not my fault. But proving it may be a different story. That woman is an attorney, and she’ll know every trick in the book to get out of this and lay the blame on me.”

“Where were you when it happened?” I asked Sherlock. “You got to the car just seconds after we hit the Jaguar.”

“I was standing in front of the bank watching Mr. Gillis film a commercial,” the young detective answered. “I noticed your Taurus driving by and waved at you, but I guess you didn’t see me. Just a split-second later, you and the Jag were colliding.”

“Even if they did cite you for the accident, our insurance would pay for the damage, wouldn’t they?” I asked, trying to comfort Mom. “It’s not that big a deal.”

Mom shook her head. “Our insurance would pay for the damage to Miss Cheatham’s Jaguar,” Mom replied, still sobbing, “but not the Taurus. I’m afraid if we can’t prove that she caused the accident, we simply lose our car.”

“But why wouldn’t they pay?” I protested. “That’s what insurance is for!”

Mom sobbed even harder. “The Taurus is seven years old, Penny. Your father dropped the collision coverage on it just last week. The only coverage we have now is liability. If I’m at fault, they’ll pay for the other car, but not for ours.”

I looked at Sherlock. “You said that the Jag ran a red light. Isn’t there some way to prove it?”

Sherlock shook his head. “Not that I know of,” he replied slowly. “It’s just my word against that of Miss Cheatham, and any other witness that thinks they saw your Mom run a red light.” He shrugged. “I guess there’s really nothing we can do.”

I was almost in tears. “Think, Sherlock! There must be a way! You have to prove that the light was green when Mom and I entered the intersection. You have to! If you don’t, we’ll lose our car!”

Sherlock drew a deep breath. “Let me think about it,” he said slowly. He studied the intersection thoughtfully.

I glanced toward the noisy crowd of “eye-witnesses.” Officer Clark was scribbling as fast as he could, trying to get the name and address of each person. The attorney was at his elbow, still loudly insisting that Mom had caused the collision. I turned away. Sherlock had told Clark that the attorney was at fault, but there had to be a way to prove it.

Sherlock snapped his fingers, and I looked at him expectantly. “I think I’ve got it, Penny!” he exclaimed. “There may be a way to prove that the Jaguar ran a red light!”

Chapter 2 – Proof

Sherlock and I are both in seventh grade at Spencerville Junior High, the school we have to attend since our town of Willoughby is too small to have a junior high. His real name is Jasper, but everyone calls him Sherlock because of his incredible mind and his ability to solve mysteries. He's a brain. Straight A's, without even trying. I don't think it's fair. He skipped third grade, so he's younger than the other kids in our class. This skinny little kid with the thick glasses is the most intelligent person in all of Willoughby.

My name is Penny Gordon, and I suppose I'm the average junior high girl. There's really nothing unusual or outstanding about me. I'm quite athletic for a girl, but I have to study day and night just to maintain a B average in school. I'm tall and thin, with far more than my share of freckles and

long, blond hair that has a mind of its own. When I was in fourth grade I talked Mom into getting me a perm for my birthday, but my hair came out looking like a yellow scrub pad. I'll just have to put up with straight hair.

Sherlock and I both come from Christian families, and we both received the Lord Jesus as our own Savior when we were young. We both attend Calvary Baptist Church, the only Gospel preaching church in the dinky little town of Willoughby. Our town has three churches, two grocery stores, and three gas stations. Our mayor pumps gas at one of the stations. As you can probably imagine, life in Willoughby is about as exciting as watching a mud puddle evaporate.

Minutes after the accident, the traffic on Main Street had been brought to a stop by Officer Bill's outstretched hand, so Sherlock hurried across at the corner. I scrambled to catch up with him. "What are you thinking?" I called. "Is there a way to prove that my mom's not at fault?"

As we stepped up on the curb in front of the First National Bank of Willoughby, I glanced up and got the surprise of my life. The bank was gone!

The First National Bank of Willoughby was one of the oldest and ugliest buildings in our little town. It was built of dull, gray cement and had ugly green stains on the walls, making it look like some sort of ancient prison or fortress. Sherlock always says that George Washington's grandfather probably built it.

Well anyway, the ugly old bank building was gone, and in its place stood a modern-looking structure of gleaming steel and glass. "What happened to the bank?" I asked in amazement. "Where's the old building?"

"This is the old building," Sherlock informed me. "They just gave it a face-lift. Mr. Gillis and the board of directors decided that the bank needed a new image—you know, to show that it was keeping up with the changing times. State of the art technology and all that. In fact, that's why Mr. Gillis was filming the bank commercial just now."

I glanced up to notice two big TV cameras on the sidewalk in front of the bank. Mr. Gillis, the bank manager, was standing on a small wooden platform at the edge of the sidewalk. Behind him, a brand new, high-tech digital sign was displaying the time and temperature. I figured that the TV

cameras must be turned off at the moment because Mr. Gillis and the camera crews were standing around staring at the accident in the middle of the intersection.

Sherlock rushed up to Mr. Gillis. "May I see the footage you just shot?" he asked. "It's important."

Ordinarily you'd think that a busy man like a bank manager wouldn't have time for a twelve-year-old kid, but Sherlock was on pretty good terms with Mr. Gillis. Just a few months ago, the bank was robbed by two men wearing disguises. The armored truck had just made a payroll delivery moments before the robbery, and the robbers got \$180,000 in cash. When Sherlock figured out a way to identify the men and recover the loot, Mr. Gillis became one of his biggest fans.

Mr. Gillis nodded as he stepped down from the little platform. "Sure thing, Sherlock." He hurried over to one of the camera crew. "Hey Mac, rewind the tape and bring it up on the monitor, would you?"

I had already guessed what Sherlock was thinking. "No good, Sherlock," I lamented. "The cameras are facing the bank. They won't show the traffic light."

Sherlock gave me a funny look and turned back to watch the little monitor beside the camera. Moments later, the image of Mr. Gillis appeared on the screen. The camera angle was planned so that the bank sign was plainly visible behind his left shoulder. "...built on three generations of integrity and trust," he was saying. "The First National Bank of Willoughby has been serving businesses and families just like yours for more than sixty years. With a rock solid heritage of fidelity and trust, Willoughby's own bank has the cutting edge technology to take you into the future. Your financial picture—"

At that moment, the noise of screeching tires interrupted the commercial, followed by the heart-stopping sound of a Taurus crashing into a Jaguar. On the screen, a look of horror crossed Mr. Gillis' face. He stood staring, mouth open, for several seconds. Then the screen went blank at the point where the cameraman had switched off the camera.

Sherlock was ecstatic. "Yes!" he shouted. "Yes! Just what we needed!" He whirled toward me with a look of excitement on his thin face. "Penny, here's the proof we need!"

I didn't understand. "But how does this prove anything?" I questioned. "The video doesn't show the traffic light."

"It doesn't have to," Sherlock told me. He peeled off his wristwatch and pushed a button, then handed it to me. "Here. Time the traffic light cycle. This button starts and stops the stopwatch, and this one will reset it."

"You want me to do what?"

"Time the traffic light cycle," he repeated patiently. "Watch the light. The instant it turns green, start the stopwatch. Let it run through the whole cycle. When the light turns green again, stop the watch."

I was beginning to catch on. "Gotcha," I told him, but he had already turned back and was asking the cameraman to rewind the videotape.

The light turned green, so I started the stopwatch. Tiny numerals on the face of the watch were changing so fast that they were impossible to read. I let the watch continue to run as the light turned red, and then stood with my finger poised over the button, waiting for the light to turn green again.

Green! I pushed the button. “The time was 52.61 seconds,” I called to Sherlock. I noticed that he had borrowed a watch and was standing in front of the TV monitor, watch in hand, watching intently.

“Good,” he answered, without turning. “Clear the watch and time it again.”

I shrugged, cleared the watch, and waited for the light to change to red so I could time the cycle again. To my surprise, the time was slightly longer on the second cycle. “This time it was 52.69 seconds,” I announced.

Sherlock took the watch from my hand and looked at it. “We’ll average it at 52.65 seconds,” he said. He cleared the stopwatch. Watching the traffic light closely, he started the watch again the instant the light turned red, then spun around and watched the bank sign. When the time display changed from 10:23 to 10:24, he stopped the watch. “The traffic light changed to red 43.73 seconds before the bank sign changed.”

I was confused. “Sherlock, what’s the point?” I asked. “What does all this have to do with the traffic accident?”

He waved his hand for me to be quiet. “Six minutes, sixteen point twenty-seven seconds,” he whispered, “divided

by 52.65.” I realized that he was doing some rapid calculations in his head. Seconds later, he turned to me with a look of triumph on his thin face. “Yes! Penny, the Jag entered the intersection approximately 6.41 seconds *after* the light changed to red! We have proof!”

I wasn’t following him at all. “How do you know *that?*” I challenged.

“The accident took place exactly 15.63 seconds after the bank display changed to 10:17,” he explained. “The bank video proves that. The light just now changed to red, which would be a red light for the Jag, 16.27 seconds after the display turned to 10:23.”

I frowned. “So?”

“The complete traffic light cycle takes 52.65 seconds, give or take a few hundredths of a second for human error in our timing. If you go back seven complete cycles, you find that the light changed to red 8.72 seconds after the bank sign changed to 10:17. That’s 6.91 seconds *before* the collision took place! If Miss Cheatham was traveling at thirty miles an hour—and I believe she was going much faster—it would take her exactly half a second to travel twenty-two feet, which is the

approximate distance that she traveled across the intersection before the collision occurred. I figure she entered the intersection 6.41 seconds *after* the light changed.”

I stared at Sherlock. “Incredible!” I exclaimed. “This proves that the Jag did run a red light! Wait till that attorney hears this.”

He nodded. “Let’s go tell Officer Clark.”

We crossed the street again and hurried over in front of The Electric Beach where the attorney was still harassing Officer Clark. The look on his face told me that he was just about out of patience with her. Sherlock grabbed Clark’s sleeve in order to get his attention. “Sir, would you come across to the bank for just a moment? We have evidence that the Jaguar ran a red light. Miss Cheatham entered the intersection more than six seconds after the light changed, and I can prove it!”

Laura Cheatham snorted. “These stupid kids!” She pointed a well-manicured finger at Sherlock and snarled, “You don’t know what you’re talking about, kid. Why don’t you get lost?”

Clark turned to Sherlock. “What’s your evidence, Sherlock?”

“Mr. Gillis was filming a commercial in front of the bank at the instant the accident occurred,” the young detective explained. “The videotape proves that the Jaguar entered the intersection at least six seconds after the light changed.”

I was watching Miss Cheatham when Sherlock said this, and you should have seen her face! An expression of panic flashed across her features for just a fraction of a second, making me think of a chipmunk that’s just been caught by a hawk. She glanced across the street toward the bank and quickly recovered her composure. “Officer, this is ridiculous,” she protested. “Those cameras aren’t even facing the intersection!”

“Come with us, sir,” Sherlock requested again. “I can prove that the Jaguar ran a red light.”

Clark and Sherlock waited at the corner for a break in the traffic. Miss Cheatham waited with them, grumbling the entire time. I dashed over to Mom. “Sherlock can prove that the Jag ran a red light, Mom! We’ll be right back.” Officer Bill brought the Main Street traffic to a halt just then and I

dashed across with Sherlock, the attorney, and the police officer.

“The sound of the collision is clearly audible on the video,” Sherlock explained, glancing from Officer Bill to the attorney, “and the bank clock—which is visible in the video—establishes that the accident occurred exactly 15.63 seconds after the clock display changed to 10:17. I’ll have Mr. Gillis show you the video in just a moment.”

“This doesn’t prove anything,” the attorney said derisively.

“Hold on, ma’am,” Sherlock said politely. “By timing the cycles of the traffic light, I was able to establish that the light changed to red exactly 8.72 seconds after the clock changed, or 6.91 seconds *before* the collision took place!”

“No way!” the indignant lawyer snapped.

Sherlock merely smiled. Handing his watch to Officer Clark, he showed the man how to time the traffic light against the moment that the bank sign changed the time display in order to establish the time that the light changed. Then he had the cameraman rewind the video and play it. The attorney frowned with displeasure and the police officer grinned in

admiration as they leaned over Sherlock’s shoulder, watching him closely as he did the arithmetic on the palm of his hand in green ink. “There you have it,” he said with a flourish, holding his palm up triumphantly. “The traffic light changed 8.72 seconds after the bank display changed to 10:17. The collision took place 6.91 seconds later. Here’s your proof, Miss Cheatham. You ran a red light!”

Officer Clark gave a low whistle. “You’re incredible, kid!” The attorney stood quietly biting her lip as Officer Clark whipped out his ticket book and began to write her a citation. She was so angry she was trembling and she looked as if she would like to strangle somebody, namely, Sherlock and me. But Sherlock was right and she knew it, and there was nothing she could do about it.

Sherlock and I walked to the corner and waited to cross. “Thanks, Sherlock,” I said fervently. “That was magnificent! You saved my family from having to pay for another car.”

The young genius shrugged. “The evidence was there,” he said simply. “I just put the facts all together.” He grinned suddenly. “Thank the Lord that the bank video showed the clock display.”

Just then his mom pulled up to the curb in her minivan and rolled down the passenger window. “Hi, Penny! Ready, Sherlock?”

Sherlock hurried over and stuck his head in the window. “Penny and her mom are going to need a ride home, Mom. Their Taurus was totaled in an accident just now.”

Mrs. Jones looked shocked. “What happened?”

Sherlock shrugged. “Two women drivers, Mom. What do you expect?”

“Now hold on!” I protested. “Sherlock, how can you say—”

He flashed me a grin. “Just teasing you, Penny. Hop in while I go get your mom.”

“So that’s the way it happened,” I told Mrs. Jones, as I finished the story of our collision with the Jaguar. “Sherlock proved that the attorney had run a red light, so her insurance company will pay for our car. He saved us a lot of money.”

“I was thankful that the Lord used me to see that the responsibility for the accident was placed where it belonged,”

Sherlock said modestly. “I’m just glad that that arrogant woman had to face up to her responsibility.”

“I’m thankful that no one was hurt,” Mrs. Jones replied. “Cars can be replaced, but not people.”

“What about our car, Mom?” I asked. “We just left it there.”

“Officer Clark is making arrangements to have it towed,” Mom told me. “The garage and the insurance company will decide if it’s worth fixing. We’ll have to get a rental car for a few days.”

Mrs. Jones glanced at Mom. “Not to change the subject, but have you told Penny yet?”

“Told me what?” I asked. I leaned forward against the back of Mom’s seat.

“Your father and I have decided that you’re not going back to Spencerville Junior High,” Mom replied softly. “These last two weeks with this asbestos thing have opened our eyes. The school board doesn’t seem to be interested in what’s best for the students. This whole episode was ridiculous.” Mom was referring to the unexpected vacation that we had been enjoying for the last two weeks. When the school janitor

discovered asbestos in the ceiling of the band room, the school board had decided to close down the entire school until it was removed. The latest word was that it was going to take at least two more weeks.

“But where will I go?” I puzzled. “Willoughby doesn’t have a Christian school.”

“We’ve decided to home school,” Mom explained. “Even with my limited educational background, your father and I are convinced that we can do a better job than the public system. And we’ll be reinforcing the godly values we believe in, rather than allowing a godless, humanistic system to try to tear them down.”

“Oh, Mom,” I said, suddenly overcome with emotion.

“I know it probably comes as something of a shock,” Mom replied, “and the idea will take some getting used to. But in the long run, I think you’ll be glad for our decision.”

“I’m glad right now, Mom. You don’t know what a relief this is. Spencerville Junior High was pretty rough. The language we heard in the hallways, the things the girls talked about in the bathrooms, and... Well, I never said much about

it, but I really don’t think you and Dad knew how bad it really was.”

“I doubt if most parents of kids in public schools really have any idea,” Sherlock commented.

“Sherlock,” Mrs. Jones said, “I might as well tell you, now, too. We’re going to home school, too.”

Sherlock grinned, and I said, “Yes! That will make two homeschoolers in Willoughby!”

“Well, actually, it will make seven,” Mom said. “The Diamonds are pulling their kids out, too.”

“What about—” I paused, not quite sure how to phrase the question without hurting Mom’s feelings.

“What about what, Sweetheart?”

“Well, you’re... you’re not really a qualified teacher, and neither is Mrs. Jones or Mrs. Diamond. Will our education be... you know, will it be as good as it would if we stayed in public school?”

“I’m sure it will, Sweetheart,” Mom replied. “We’ll be using some quality curriculum, and we’ll do our best.”

“Academically, home schoolers are usually miles ahead of their public school counterparts,” Sherlock told me. “A

recent article in *The Freeman* reported that the average home schooled student places in the eighty-fifth percentile on standardized achievement tests, while the average public school student scores thirty-five points below that, in the fiftieth percentile! I don't think we have anything to worry about. If we work hard, our education will now be superior to what we were receiving in the public system."

"When will we get our books and stuff?" I asked.

"We ordered them this morning," Mrs. Jones replied, "but the publisher is telling us that it will take two weeks to get the materials. So it looks like this little vacation has been extended for two more weeks."

"That's OK," I declared. "Good-bye Spencerville Junior High!"

Sherlock looked thoughtful. "But this leaves Brandon alone at the public school," he said slowly, referring to a friend of ours who had recently been saved. "That's not good."

Mom turned and looked at me. "Penny, I think I'm gonna give Doctor McCulley a call and have him take a look at your head. You got quite a wallop back there."

I shrugged. "I'm fine, Mom, really I am. It still hurts a little, but it's gonna be OK."

Mom looked determined. "Just the same, I'd like for him to take a look at it and make sure you didn't get a slight concussion or something. Head injuries can be serious."

"I'm OK, Mom," I protested. "It was just a bump—no permanent damage."

"She's a blonde, Mrs. Gordon," Sherlock remarked. "It would be impossible for her to have sustained any brain damage."

I made a face at him, and he laughed. "Just kidding, Penny."

Mrs. Jones pulled the minivan into our driveway a moment later and her cell phone rang just as she braked to a stop. She picked it up. "Hello." She listened for a moment and an expression of surprise crossed her features. "When?" she asked. Then, "I don't know... we'll have to discuss it. Hold on just a minute, please."

Pushing the mute button, she turned to Mom. "This is Lisa Diamond. Her father is flying down somewhere in the Mediterranean to upgrade the computer systems on some

research ship, and he's taking Lisa along. She wants to know if Sherlock and Penny can go with them. Mr. Diamond says that the entire trip will take just over a week."

My heart leaped as she broke the news, and a thrill of excitement swept over me. If Mom and Dad let me go, it would be quite an adventure. "Can we go, Mom?" I begged. "This is the chance of a lifetime! Can we go?"

Sherlock didn't say a word; he just looked at his mom expectantly. Mrs. Jones and Mom glanced at each other and then turned back to us. "We'll have to wait and see, Penny," Mom replied. "I'll have to see what your father says. And you're not going anywhere until we clear it with Doctor McCulley."

Sherlock gave his mom a pleading look. His eyes looked huge behind his thick glasses. Mrs. Jones laughed. "OK, you two, that's enough of this! Your father and I will discuss this, Sherlock, and let you know. Unless he comes up with some good reason, I don't see why you can't go. We can't start school for another two weeks, anyway."

My heart was pounding at the idea of a trip to the Mediterranean. *Lord Jesus*, I prayed silently, *please let our*

parents say yes! Please, Lord, work it out so that we can go. Don't let Doctor McCulley find anything wrong that would stop me from going on this trip. Please, Lord!

Sherlock leaned toward me. "This trip is gonna be awesome!" he whispered. "Imagine! A chance to visit the Mediterranean!"

Chapter 3 – Mysterious Passenger

The powerful jet engines whined as the 757 climbed above the clouds. The late afternoon sun reflected off the top of the wing, nearly blinding me, so Lisa pulled down the shade over the little oval window. I leaned back in my seat and let out a long sigh. Everything had happened so quickly. Mom and Dad trusted Mr. Diamond implicitly, so after a ten-minute phone discussion, they had given permission for me to make the trip. One of Mr. Diamond's staff had taken Sherlock and me to get our passport photos, then rushed the paperwork through the process, resulting in us having our passports in less than four hours.

I glanced over at Lisa. "It's hard to believe that we'll be in Spain in just a few hours," I whispered. "I can't believe

that your dad was able to get our passports so quickly. Don't they usually take several weeks?"

"They can," Lisa replied, flipping her dark hair back over her shoulder with a slender hand. "But if you're willing to pay the extra fees, you can have them in a matter of hours. Daddy wanted you and Sherlock to go, so he paid the expediting fees."

I grinned. "Must be nice to be a millionaire!"

Lisa gave me a reproving look. "Penny! I thought you got over that idea when I was kidnapped!"

I shrugged. "OK, so there are some problems with having money. But it sure came in handy this time."

"I'm just thankful that Doctor McCulley said you could go."

"I'm OK," I replied. "Doc examined my head, shined a little light in my eyes for a couple of minutes, and told Mom that it was just a bad bump." I pushed the little silver button on the side of my armrest, leaned the seat back in the reclining position, and let out a sigh of contentment. "I still can't believe that we're actually making this trip. This is gonna be so awesome."

“We’ll be in Spain sometime tomorrow morning,” she replied. “We’ll fly into New York, then fly a 747 night flight across to Barcelona, Spain.” She smiled at me. “I’m sure glad that you and Sherlock are going with us.”

Lisa Diamond is one of the best Christians I know. She’s beautiful, with long, raven black hair and the most beautiful face that God ever created. She’s also rich. Her dad, Larry Diamond, is the primary owner and CEO of Diamond Computer Technology, a highly successful company. But you’d never guess that Lisa is the daughter of a multi-millionaire. She’s the friendliest, most compassionate person I’ve ever met, with a heart for God and a desire to see souls saved. I’ve known her less than three months but I’ve already seen her lead two people to the Lord. Lisa and I are becoming good friends.

“So tell me about the ship,” I said. “This whole thing has happened so fast that we haven’t even heard all the details. And what kind of computer project is your dad working on?”

“The *Endeavor II* is a research ship that belongs to the Atlantic Oceanic Institute,” Lisa replied. “The ship is home to the *Odyssey*, a 19-foot, deep-sea mini-sub that can dive down

to 12,000 feet. The Institute uses the *Odyssey* to study ocean currents, marine biology, and stuff like that.”

“And your dad knows somebody on the ship, right?”

“Daddy went to school with Captain Stevens,” Lisa told me. “When the Institute authorized a new computer system for the ship, Captain Stevens contracted with Diamond Computers to install the system and get it up and running. Daddy decided to do the work himself, rather than sending a couple of technicians. He says it’s a working vacation.”

“How come he invited us, instead of taking your mom?” I asked.

“Mom was going to go, but she got sick last night and decided not to. I really think that she was just nervous about the trip. She doesn’t like boats and water, and I really don’t think she was too excited about spending a week on board a ship.”

“She doesn’t like water?” I echoed. “Then what about that big, fancy, guitar-shaped swimming pool that goes right into your mom and dad’s bedroom?”

“Oh, she likes to swim,” Lisa answered, “as long as it’s in a swimming pool. But she doesn’t like the ocean. She says the constant motion makes her seasick.”

A loud chime sounded just then, and the little seat belt signs over our heads winked out. I leaned out into the aisle and looked forward to where Sherlock and Mr. Diamond were seated three rows ahead of us, laughing and talking together. “I’m sure glad your dad invited us,” I said again.

Lisa smiled. “I’m glad, too,” she said softly.

I glanced toward the back of the plane, and my heart seemed to skip a beat. A dark-skinned man seated across the aisle about four rows back was staring straight at me! He wasn’t just a stranger watching the other passengers in the cabin; he was staring at me like he knew who I was, or something. It was frightening. When he realized that I had noticed him, he immediately raised his newspaper so that it covered his face.

I waited a couple of minutes and then glanced back at the man. He was still watching me! Just like before, he quickly raised his newspaper when he saw me looking at him. *See Penny*, I told myself, *it wasn’t just your imagination!*

I turned back around and Lisa noticed that something was troubling me. “What’s the matter?” she asked. “You look like you’ve just seen a ghost! Or, as Sherlock would call it, a disembodied spirit!”

“This was just as bad,” I told her. “There’s a man back there—I think he’s Iranian or something—and he’s watching us! Well, he’s watching *me*, anyway. Every time I look back there he raises his newspaper so I can’t see him, but I know he’s watching me!”

Lisa shook her head. “You’ve been hanging around Sherlock too much,” she said with a laugh. “You’ve seen him capture crooks two or three times, and now you’re looking for a crook behind every tree.”

“But we do have to be careful,” I told her. “Stranger danger and all that. And this guy looks like a crook.”

“What do crooks look like?” she challenged. “Sometimes the little old grandmother-types are just as dangerous as the gangster-types. My dad says that you can’t evaluate a person just by looking at him or her.”

“Well, this guy just looks like a crook,” I said lamely.

Lisa made a fist and gently thumped my arm. “Well, I’m sure he isn’t watching you,” she assured me. “It’s just your imagination.” She pulled the airline magazine from the pocket in front of her seat and began to page through it.

I waited a couple more minutes and then glanced back toward the strange man. His seat was empty.

After waiting almost two and a half hours in the JFK airport, we took off for Spain aboard a luxurious 747. The plane was huge, much bigger than the 757 we had flown on, and I was surprised. I just figured the bigger the number, the bigger the plane. We had been assigned the four seats in the center section of Row 32, so we all got to sit together. Lisa began paging through a magazine as the plane climbed to our cruising altitude. “Here’s a new blonde joke,” she said. “What do you say to an intelligent blonde?”

“I don’t know,” I muttered.

“Don’t worry about it,” she answered. “You’ll never meet one.”

I groaned.

“What do you call it when a blonde dyes her hair?”

I shrugged. “What?”

“Artificial intelligence.”

“What’s black and blue and brown and lying in a ditch?” I asked.

Lisa shrugged. “I give up.”

“A brunette who has told too many blonde jokes,” I told her with a grin. “Now, why are so many blonde jokes one-liners?”

Lisa shrugged again. “Why?”

“So brunettes can remember them,” I teased.

Lisa laughed. “OK, we’re even.”

The flight attendants came by just moments later and served us a pretty decent supper of roast turkey, mixed vegetables, and mashed potatoes and gravy, along with a fruit cup and juice. I’ve always heard people complain about the food on airlines, but this was my first flight, and I thought the food was pretty good. After the flight attendants came back and picked up our trays, I decided to head for the ladies’ room at the rear of the 747.

The small, lighted sign above the bathroom door said “Occupied”, so I turned to use the other one. Another “Occupied” sign. OK, so I was going to have to wait. The flight attendant was trying to move a little food cart out of the little kitchen area, so I stepped forward into the aisle to get out of her way. Just then, the plane dropped abruptly and we were bounced around like Ping-Pong balls in the back of a truck with bad shocks.

The plane lurched to the left and then dropped suddenly, and I found myself thrown backward into the seats. I landed squarely in the lap of one of the other passengers, crushing his newspaper flat against his face. “Excuse me, please,” I said with a nervous laugh as I attempted to scramble to my feet. The plane lurched again, and I was thrown against the man for the second time. “I’m trying to leave, really, I am,” I said, still struggling to regain my balance and scramble off the man.

The newspaper came down, and my heart stopped for a second or two. The passenger was the Iranian man from the earlier flight, the mystery man who had been watching me so

intently! I forgot all about using the bathroom and fled to my seat.

“He’s on this plane!” I whispered urgently to Lisa, sliding into my seat. “The man from the other flight!”

Mr. Diamond frowned. “What man?”

“Penny thought that someone was watching her this afternoon,” Lisa explained. She turned to me. “Is that the man you’re talking about?”

I nodded nervously.

Sherlock leaned over. “Who is he?”

“Just someone on the plane,” I stammered. “He looks like he’s Iranian or something. He was four rows behind us on the other flight and every time I looked back, he was watching me!”

Mr. Diamond squeezed my hand. “I’ll check it out,” he said softly. “Where is he sitting?”

“He’s in the aisle seat in the left section of the plane, second row from the back,” I replied. “He’s wearing black pants and a dark-colored shirt.”

“That would be seat 58C,” Sherlock informed us. I stared at him.

Mr. Diamond disappeared down the aisle. “Are you sure it’s the same man?” Lisa asked in a whisper.

“Positive,” I told her. “I *know* it is.”

“So he’s on the same flight,” Sherlock chimed in.

“Why all the concern?”

“Sherlock, what if he’s following us? You should have seen the way he was looking at me on the other plane! And why would he be on this flight?”

Sherlock didn’t seem at all concerned. “It’s just a coincidence, Penny. He’s allowed to go to Spain, too, you know.”

“But why was he watching me the way he was?”

“Maybe he was thinking up some new blonde jokes.”

I made a face at him. “I don’t think that’s funny.”

Mr. Diamond squeezed past us and dropped into his seat. He leaned over to me. “Seat 58C is empty,” he told me in a quiet voice, “and no one else matching your description is seated anywhere in the area.”

The mystery man had disappeared.

A few hours later, we were claiming our luggage at the *Aeropuerto de Barcelona* baggage carousel. A skycap loaded all our suitcases on a big cart and led us through the airport to a helipad where an awesome-looking helicopter waited with engine roaring. We climbed aboard, and I realized that I was trembling with excitement, having never ridden in a helicopter before. The helicopter engine roared as the craft lifted off from the asphalt. I watched in fascination as the airport fell away beneath us. Within minutes we were at an altitude of several hundred feet, cruising above the blue-green waters of the Mediterranean. I sat back in my seat and adjusted my headset, trying to find a more comfortable position for my ears. Each of us had our own headset to protect us from some of the engine noise and enable us to communicate with each other.

“Sunrise came mighty early today, didn’t it, Penny?” Mr. Diamond’s voice rang right in my headset, causing me to jump. Mr. Diamond laughed. “Sorry, Penny, didn’t mean to frighten you.”

I glanced at my watch. “How come it got light so early?” I asked in confusion. “My watch says 4:30 a.m., but outside it looks like it’s almost noon.”

Mr. Diamond laughed. “Actually, it’s 10:30 here,” he replied. “We lost six hours because we flew east.”

“Lost six hours?” I echoed. “You mean that they just took a six-hour chunk out of my life?”

Lisa’s dad laughed again. “They’ll give it back when we head west again, Penny. I promise.”

I shook my head. It was all so confusing. I glanced forward at Sherlock, who was trying to talk the pilot into letting him try to fly the helicopter, then at Lisa, who was peering out the window at the water below. I sat back, yawned, and closed my eyes for a minute. I must have fallen asleep, because the next thing I knew, Lisa was shaking my arm. “Penny, wake up! We’re at the *Endeavor II*!”

I leaned across her and looked out the window. The helicopter was dropping fast. All I could see below us was water and a small, white ship over to our left. As I watched, the ship grew larger and larger. Moments later I felt a small thump. The whine of the helicopter engine changed in pitch, then grew quieter, and I realized that we had landed right on the ship. Lisa and I took our headsets off and stowed them up behind the seat.

The pilot flipped several switches and then turned and nodded at Mr. Diamond, who opened the little door beside him and stepped out. Lisa and I followed him. We found ourselves standing on a little platform just twelve or fourteen feet across, and at least ten feet above the deck. It was rather scary. Mr. Diamond grabbed us both by the arms and led us to one edge of the platform. “Careful,” he shouted above the noise of the helicopter. “Watch your step!”

Lisa and I walked down a steep set of stairs and stood quietly on the steel deck. We were aboard the *Endeavor II*. I turned and looked back at the helipad, which was the helicopter landing platform, and realized that it was actually the roof of some sort of control booth. For just a moment, my surroundings seemed to sway back and forth, and I felt very dizzy. I clutched at Lisa to keep myself from falling.

“Penny, what’s wrong?” she asked in alarm. She grabbed my shoulders to steady me. “You don’t look good!”

“I just feel dizzy,” I answered weakly. “I’ll be all right in a minute.”

“It’s the whack on the head you got in the accident,” she told me. “It may have done more than you realize!”

“Doctor McCulley said I’m all right,” I protested. “I’ll be OK.” Moments later, the dizziness passed and I felt fine.

Two crewmembers dressed in white hurried past us up the stairs to the helipad and began to unload our luggage from the storage compartments of the helicopter. Mr. Diamond and Sherlock struggled down the stairs, loaded with our suitcases and other stuff. The two crewmembers brought the rest of it. The helicopter rotor began to whirl faster and faster. With a whining roar, the craft lifted free from the helipad and disappeared out over the water.

As I watched the helicopter grow smaller and smaller, a lonely, desolate feeling swept over me. It was as though we were being marooned on a tiny island in the middle of the ocean, except that we were standing on the steel deck of a ship instead of the sandy shore of an island. For just a moment I felt weak and dizzy again, and I wondered if it had anything to do with the bump on the head I had gotten when our Taurus plowed into the Jaguar.

“Welcome to the *Endeavor III*!” a cheerful voice boomed, and we all turned to see a stocky man in an immaculate white uniform striding toward us. An impressive

hat with gold braid shaded his tanned face, and I knew immediately that he was Captain Stevens. Brilliant blue eyes sparkled with friendliness, and a stiff, white mustache rested just above a row of the whitest teeth I have ever seen. The captain swept off his hat, revealing a shock of unruly white hair that looked as if it hadn’t seen a comb for a long time. “Good to have you aboard.” I liked this man immediately.

“Marshall Stevens,” Mr. Diamond boomed, “good to see you, pal!” He shook hands briskly with the captain.

“That’s Captain Stevens to you, sir,” the other man said, and both men laughed heartily. “I’m glad you made it. Another five minutes and we would have had to leave without you.”

Mr. Diamond looked puzzled. “What do you mean?”

Captain Stevens shook a small sheaf of papers. “The Institute just faxed me some emergency orders,” he replied. “We’re setting a course for a point in the Atlantic just off the coast of Portugal, where we’ll undertake a new assignment.” He dropped his hand to his side. “Hopefully, this new assignment won’t interfere with your work in the computer lab.”

While the captain talked, I noticed that Sherlock had cocked his head sideways and was reading the top sheet of the faxes in the man's hand. His eyes suddenly widened in astonishment, and I wondered what he had read that was so amazing. I edged closer, but Sherlock was in the way and I couldn't get close enough to read the paper.

Captain Stevens looked at each of us in turn. "It's good to have you aboard. Sorry I can't give you a tour of the ship just now, but I have to hurry back to the bridge. We get underway in less than five minutes." He hurried across the deck and climbed some stairs to the next level and then disappeared through a doorway.

The two crewmen stepped forward with our luggage. "Welcome aboard the *Endeavor II*," the taller of the two crewmen said with a friendly grin. "I'm Dan Hawkins, the ship's Bos'n, and this is Mark Summers, ship's electrician. We'll help you get settled in."

"What does a ship's Bos'n do?" I asked Sherlock in a whisper as Mr. Diamond shook hands with the two men.

"Bos'n is short for 'Boatswain'," Sherlock replied. "He's the immediate supervisor of the deck crew under the

Chief Mate. The Bos'n is the key figure in the execution of deck and over-the-side work. He oversees the operation of the ship's equipment including winches and cranes and the maintenance of the ship's structure."

Hawkins overheard Sherlock's answer and turned to stare at him incredulously. "How did you know that, kid?"

Sherlock shrugged. "I did some reading yesterday afternoon before we left for the airport."

The two men looked at each other and laughed, shaking their heads. "We'll show you to your berths," Hawkins said, leading the way across the deck. Lisa and Mr. Diamond fell into step right behind them, but Sherlock grabbed my elbow and held me back a few steps.

Sherlock leaned close. "An emergency military assignment," he whispered. Behind those thick glasses of his, his eyes sparkled with anticipation. "Something really big is up, or they wouldn't be commandeering a civilian ship like this."

"Oh, come on, Sherlock!" I chided. "How do you know that? We're probably just going to count dolphins or something."

“I saw the top page of the fax from the Institute,” he insisted. “The *Endeavor II* is going to rendezvous with some military ships. Some high-ranking military personnel are coming aboard. Captain Stevens is to place the ship at their disposal and take orders from them. The whole operation is to be kept top secret, and they want everything to appear to be ‘business as usual.’ The ship supposedly is going to be making hydrographic surveys, but that’s just a cover story.”

“You’re kidding! What does the military want with the *Endeavor II*?”

“They’re gonna use the *Odyssey*,” he told me breathlessly. “I think they’re looking for something.”

Lisa turned and noticed that we were not with them. “Come on, you guys,” she called. “What’s keeping you?”

“We’re coming!” Sherlock called. “Come on, we’d better go,” he told me in a quiet voice. “Don’t say anything about what I just told you.” We hurried to catch up to the others and I shivered as a cold premonition of danger crept down my spine.

Chapter 4 – The *Endeavor II*

I couldn’t believe what Sherlock had just told me. It seemed pretty far out, but I had been around Sherlock long enough to know that he didn’t just make things up. If he said that the *Endeavor II* was going to be involved in some top-secret military operation, then, well, it had to be true. My heart pounded with anticipation. “Do you think they’ll kick us off the ship?” I asked. “You know, since it’s supposed to be top-secret and we’re civilians?”

Sherlock frowned. “I guess we’ll have to wait and see,” he replied thoughtfully. “The fax from the Institute said that Captain Stevens was to do everything he could to make the operation seem as if nothing was out of the ordinary. They have to keep the crew aboard to operate the ship; but if they kick all the scientists and other civilians off, that would alert everyone that something unusual was taking place.” He

shrugged. “Who knows? Maybe they’ll let us stay just for that reason.”

Lisa turned around just then and noticed that we were still lagging behind. “Come on, you guys,” she called. “You’re gonna get lost.”

Sherlock and I hurried to catch up. We followed them across the deck, through a doorway, and down three flights of stairs. “Your staterooms are on the first platform deck,” Dan Hawkins told us. “That’s one level below the main deck. The generator room, communications room, and workshop are all on this level, as well as the staterooms for most of our complement of scientists.”

“What deck did we just come from?” Mr. Diamond asked.

“That’s the 02 level,” Sherlock replied. “The ship’s infirmary is on that level, as well as berths for many of the ship’s officers, and—” He stopped suddenly, embarrassed, as he realized that he had spoken out of turn. “I’m sorry,” he apologized.

Hawkins stared at him. “What are you, kid, some sort of walking encyclopedia?”

Sherlock was embarrassed. “I went on the Internet yesterday,” he explained quietly, “and went to the Atlantic Oceanic Institute’s website. I found schematics and deck layouts for the *Endeavor II*.”

“And memorized them,” I added.

Sherlock shrugged. “I couldn’t help it.”

The two crewmen looked at each other, and then back at Sherlock. “Tell me the name of the small structure immediately beneath the helipad,” Summers said.

“The aft control station,” my friend responded, “housing controls for the A-frame launching crane and the two aft winches.”

“Where’s the Hydro Lab?” Hawkins asked.

“Amidships,” Sherlock answered, “Main deck, port side.” I already knew that “port” is the left side of the ship when one is facing the bow, and “starboard” was the right side, so I knew what he was talking about. I think “amidships” means somewhere in the middle of the ship.

Summers laughed. “He probably knows the *Endeavor II* better than Captain Stevens does.”

We reached the first platform deck just then, stepped through a doorway, and walked down a short passageway. We followed the men around a turn to the right. “The two staterooms on the right are yours,” Hawkins told us. “Who wants the berth with the ocean view?”

“We do,” I said, without thinking, then instantly regretted sounding so selfish.

“You got it,” Hawkins replied. He set our luggage on the deck, reached in his pocket, and pulled out four little white plastic cards. Glancing at the numbers on the cards, he handed one each to Lisa and me, then handed the other two to Sherlock and Mr. Diamond.

“What are these?” I asked. The plastic cards were about the size and thickness of a credit card, but had a number of little round holes punched in them.

“Ving cards,” Hawkins replied. “That’s your room key. Just insert it in the little slot beneath the door handle, turn the handle and open the door, then remove the card.”

I wrinkled my nose as I studied the plastic card. “These are keys? How do they work?”

“The pins in the lock have to match up with the holes in the card,” he replied. “If the holes aren’t in the right places, the lock won’t open.”

“These are weird,” I said.

“A lot of hotels now use them,” the man replied. “They’re more secure than a regular key-type lock. The Ving lock can’t be picked or forced. Your encyclopedia friend here could probably tell you how many different lock combinations are possible with a Ving card.”

“Twenty-eight thousand, eight hundred,” Sherlock replied without hesitation.

Hawkins and Summers laughed in amazement. Sherlock grinned. “Actually, I just made that figure up,” he confessed, “but I could easily find out for you.”

Hawkins shook hands with Mr. Diamond. “Good to have you aboard, sir. I trust that your week with us will be a pleasant one.” He and Summers said good-bye and disappeared around the corner.

“Let’s check out the rooms,” Lisa said. Inserting my Ving card into the little slot below the door handle, I pulled down on the handle and opened the door. The stateroom was

tiny, with a double bunk against one wall and a little round porthole over the top bunk. A chest of drawers and a small desk occupied another wall. (I learned later that the “walls” on ships are called “bulkheads”, so I’m trying to learn to call them that.) I dragged my heavy suitcase into the middle of the room. There was a narrow door to my right so I stepped through it and found myself in a tiny bathroom. A door on the opposite side of the bathroom opened into the stateroom that Sherlock and Mr. Diamond were sharing.

“This little room sure is cozy,” Lisa remarked, as we started putting our clothes away in the little chest of drawers. She turned and looked at the bunk bed. “Top or bottom bunk?”

I hesitated. “Which do you want?”

She shrugged. “Doesn’t make a bit of difference, as long as it’s horizontal.”

“I’ll take the top bunk, then,” I said, scrambling up as I said it. I leaned across the bed and looked out the little porthole. The surface of the water was just a few feet below. “Hey, we’re moving!”

Lisa laughed. “Didn’t you feel the vibrations in the deck when we started?”

“I guess I didn’t notice,” I told her. I turned and peered out the porthole again. The surface of the gray-blue water was alive with motion, glittering and sparkling in the brilliance of the midday sun. The horizon seemed to rise and fall gently as the ship rocked gently. As I watched, a snowy-white seagull soared lazily above the swells. It was a fascinating sight. I love the ocean.

A knock sounded on our door moments later, and Lisa opened it to find a young woman with shoulder length brown hair and braces on her teeth. “I’m Marcia Parris,” the woman said with a smile. “I’m the mess attendant. Captain Stevens would like you to join him at his table for lunch. Can you be ready in fifteen minutes?”

“Where’s the lunch room?” I asked.

Miss Parris laughed. “On ship we call it the ‘dining saloon’ or the ‘mess deck’. It’s on the 01 level. I’ll send someone down in a few minutes to show you the way.”

Sherlock slipped into the passageway just then. “I know right where it is,” he told her. “I can save you the trouble of sending someone for us.”

The woman shrugged. "It's no problem." She laughed. "I wouldn't want you to get lost your first day aboard ship."

Sherlock smiled. "Please tell the captain that we accept his invitation. We'll be there in fifteen minutes." The mess attendant nodded and was gone.

Sherlock looked at his watch. "We have nearly fifteen minutes. Let's explore the ship."

Mr. Diamond stepped out of his stateroom. "Where are you all heading?"

"We were just going to explore, Daddy," Lisa replied.

Mr. Diamond frowned thoughtfully. "I just heard the mess attendant say that we're to be at lunch with Captain Stevens in fifteen minutes. It will take a few minutes to find the dining saloon. We're not going to be late."

"I know right where it is, sir," Sherlock said. "What if we meet you right back here in exactly eight minutes, and then we all go together?"

Mr. Diamond nodded. "That'll work. But don't be late."

Sherlock nodded in agreement. We hurried down the passageway, then up the stairs to the main deck. After walking

down a short passageway, we opened a door and found ourselves in the open air. We headed aft, which means that we were going to the stern, or back part of the ship. "I want to see the *Odyssey*," Sherlock told us.

When we reached the stern of the ship, we saw a huge, A-frame crane that looked like something a kid would build with a giant building set. The thing must have been thirty feet tall, and looked like it was sturdy enough to lift a house. "That's used to launch the *Odyssey*," Sherlock told us. He stood under the center of the crane, staring up in fascination at the structure.

I noticed little steel rails like railroad tracks under Sherlock's feet. They were recessed into the deck so that we didn't trip over them. They started at a point directly beneath the A-frame crane and led forward, so I turned around to see where they led. I followed the tracks through a huge sliding door with windows in it, kind of like an over-sized garage door. Sitting on what looked like a miniature railroad car was the strangest craft I have ever seen. Imagine a short, fat white whale with a huge, squarish fin on its back, and you have a

rough idea of what I was seeing. The thing was about twelve feet tall, and nearly twenty feet long.

“Sherlock! Lisa! Come here! I found some kind of a strange submarine or something!”

My friends hurried through the huge door and stood staring at the strange craft. “The *Odyssey*!” Sherlock said, with a note of awe in his voice. He stepped closer, reaching out to touch the side of the craft slowly, almost reverently.

“This is the *Odyssey*?”

Sherlock nodded at me. And just as I expected, he knew all about it. “This little jewel has a two-inch-thick, titanium alloy pressure hull, which enables it to safely descend to depths of 12,000 feet. It was built in 1987 at cost of three-and-a-half million dollars. The minisub carries a crew of two, with room for one observer.”

Sherlock stared up at the minisub as he talked. “Three one-thousand pound silver-zinc batteries power the two three-horsepower lift propellers at the sides and the five-horsepower thrust propeller at the rear. The *Odyssey* is equipped with two-way radio, underwater telephone, advanced navigational equipment, high-intensity searchlights, sonar and object-

detecting equipment, and both still and video cameras. The sub cruises at three knots, which is a little over three miles an hour, and is capable of diving for eight hours at a time. But the life-support system can keep three people alive for up to forty-eight hours in an emergency.”

Lisa walked around to the tail. “How do they make it dive, and then come back up?”

“Special ballast tanks are flooded with water to make it dive,” Sherlock told her. “When the crew wishes to return to the surface, they drop a 224-pound diving weight and use compressed air to clear the water from the ballast tanks. To move the sub’s bow up or down, 180 pounds of mercury can be pumped back and forth between two tanks in the bow and stern.”

“But how do you know all this?” I asked.

“I just went to the Institute’s website,” he replied. He looked at his watch. “I guess we have just a minute of two more to look around the hangar, then we’d better head back to the staterooms and meet Mr. Diamond.”

I glanced around the hangar. A workbench ran the entire length of the bulkhead on the right, uh, starboard side of

the *Odyssey*. Machinery, tools and equipment were neatly arranged on the other two sides. A portable crane hung from an overhead track directly over the minisub, and a thick, black electrical cable snaked from the front of a black and red machine to a connection on the side of the craft. The machine was making a faint humming noise, and I guessed that it was charging the *Odyssey*'s batteries.

"We'd better get back," Sherlock suggested, and we hurried back to meet Mr. Diamond for lunch.

We reached the dining saloon just as Captain Stevens did. "Hello, there," he greeted us. "Were the accommodations to your liking?"

"We're fine," Mr. Diamond assured him. "The staterooms are very comfortable."

"I want all four of you to sit at my table," the captain told us as we walked in together. He laughed. "Even if you don't enjoy my company, you'll find that it still affords you a definite advantage. My table gets served first."

The dining saloon was an attractive, cheerful room freshly painted blue and white. Large prints of various lighthouses decorated the bulkheads. Six stainless steel tables

with cultured marble tops and attached seats graced the room, and a bank of large windows afforded an excellent view of the sea. A long oak table with padded benches dominated one end of the room.

Captain Stevens sat at the head of the table and with a casual gesture of his thick hands indicated that we could find our own seats. He reached into his shirt pocket, took out his Ving card and a pair of sunglasses, and placed them on the table beside his plate. As we took our places around the big captain's table, a number of the ship's crew began filing in and took seats at the various tables. A tall, thin man with flaming red hair and thick glasses sauntered in with a loose-jointed gait and dropped into the seat to the captain's left.

"I'd like you to meet my Chief Mate, Todd Webster," Captain Stevens told us. "Webster, meet Larry Diamond and his daughter Lisa, and their friends, Penny Gordon and Sherlock Jones. Mr. Diamond is CEO of Diamond Computer Technology, and he's here to install the new computer system." He grinned suddenly. "I was disappointed to learn that Diamond Computers wasn't sending me their best men. I'm afraid we're stuck with Larry."

Mr. Diamond, with a perfectly straight face, replied, “We only send the best men out on the *important* jobs, Stevens. Most of my men wouldn’t be caught dead on an old tub like this.”

Captain Stevens laughed. “Let’s return thanks, shall we?” He bowed his head and began to pray, but I noticed an uncomfortable look on Chief Mate Webster’s face as we bowed our heads. “Father, thank You for giving Larry and the kids a safe trip today,” the captain prayed. “Bless their time aboard the *Endeavor II*, and guide Larry with his work in the computer lab. Thank You for this food we are about to receive. In Jesus’ name, Amen.”

“Amen,” Mr. Diamond said.

“The *Endeavor II* was launched in 1987,” Captain Stevens told us proudly, as Miss Parris served us a chilled shrimp salad. “She’s 272 feet in length with a total displacement of 3,240 tons and a top speed of 22 knots. Her claim to fame is that she’s home to the *Odyssey*, one of the best designed deep-sea submersibles in the world. We have a crew of 23, and we can accommodate a complement of 21 scientists. The work area on *Endeavor II* contains more than 3,600 square

feet of laboratory space, all of which is on the main deck. In addition to the Main Lab, which is outfitted to accommodate a changing set of needs and equipment, we have the Bio/Analytical Lab designed for handling specimens in an uncontaminated environment that maintains accurate temperature control. We have the Wet Lab for collecting and analyzing seawater specimens without contaminating them, and, of course, a well-equipped computer lab.”

He grinned. “Do I sound like a proud parent, or what?” To be honest, I don’t think he could have been any prouder if he was telling us that his two-year-old granddaughter was doing Algebra.

“I saw something about the ship having a dynamic positioning system,” Sherlock told him. “Would you describe that, please?”

“The dynamic positioning system automatically keeps the ship in one exact location anytime the *Odyssey* makes a dive,” Captain Stevens replied. “Onboard GPS units constantly monitor our position by receiving information from satellites. A computer uses this information to activate a system of

underwater thrusters, which work against the action of the wind and currents to allow us to maintain our position.”

He glanced at Mr. Diamond. “If my friend Larry Diamond here can bring us up to par without destroying the ship, our computer lab will be state-of-the-art again by this time next week. Incidentally, Larry, we received the entire shipment of computer components. The crates are waiting for you in the computer lab. We checked the manifest against your list, and it appears that everything has arrived safely.”

By the time I finished the shrimp salad, the mess attendant was serving us the main course: deep-fried scallops and crab cakes, yeast rolls, broccoli casserole and applesauce. For dessert, we had cherry turnovers and vanilla ice cream. “The food was very good,” I told Miss Parris, when she came to remove our dishes and plates. “Is there any way I could get another turnover and more ice cream? Please?”

The mess attendant nodded. “Sure. There’s plenty more. I’ll be right back.” She took a stack of plates from the table and hurried away.

“The food is fantastic, isn’t it?” I commented to Lisa.

Sherlock looked up from his second helping of scallops. “Don’t overdo it on the desserts, Penny,” he warned.

“I’m not concerned about the calories,” I replied. “In fact, I wouldn’t mind gaining a few pounds.”

“You know what you get when you take the word ‘desserts’ and turn it around backwards, don’t you?” he teased. “It’s ‘stressed!’ Eat too many desserts, and you’ll be stressed!”

“Thanks, I’ll remember that,” I replied. I reached for the turnover Miss Parris handed me.

The *Endeavor II* vibrated and pitched slightly, pounding full speed ahead as the captain gave us a quick tour after lunch. The tour took us from deck to deck as Captain Stevens proudly showed us the facilities and capabilities of the well-equipped research ship. He even took us up to the superstructure of the ship and showed us the radio/chart room, the surface control station, and the pilothouse. The tour ended, of course, with another look at the *Odyssey*. Captain Stevens grandly described the capabilities of the minisub, reciting much of the technical information that Sherlock had told us earlier.

When the tour concluded, Sherlock followed Mr. Diamond to the computer lab while Lisa and I headed back up to Level 01 to check out the library. We spent the afternoon watching videos about various topics of oceanography and marine biology. The most interesting was the one on sharks. It gave a lot of fascinating information about those incredible, vicious creatures, telling about the habitat of the various shark species, their eating habits, etc. We learned that there are about 370 different species of sharks, ranging from little six-inch ones that weigh about an ounce to 40-foot whale sharks that weigh as much as two African elephants.

“If I’m ever attacked by a shark,” I told Lisa, “I hope it’s one of those little six-inch guys.” She giggled.

The woman narrating the documentary told us that the shark was an incredible killing machine that had evolved millions of years ago, but I knew that the idea was ridiculous. If Sherlock had been watching the video, he could have reeled off all sorts of scientific data proving that the idea of sharks evolving was impossible.

After a delicious supper, all four of us had devotions together in a corner of the library, then headed for our

staterooms. We were exhausted. I fell asleep almost immediately.

I had just been asleep a few minutes when I heard a faint knock at our door. I slipped from my bunk and opened it quietly, surprised to see Sherlock standing there in his pajamas. “Sherlock! What do you want?”

“Come out on the deck, Penny,” he said quietly, with a note of subdued excitement in his voice. “The bioluminescence is awesome tonight!”

“The what?” I yawned, slightly irritated that he had gotten me out of bed to see something that only a brain like him would find interesting. At the moment, I was more interested in getting some sleep.

“Bioluminescence,” he repeated. “Tiny light-emitting organisms in the sea that glow when they are disturbed. I told you about it one time, remember?”

I sighed and followed him down the passageway, intending to take a look at whatever it was that had him so excited, and then get back to bed and get some sleep. We slipped out into the darkness of the night, closing the passageway door quietly behind us. The deck felt cold beneath

my bare feet, and a slight breeze gently ruffled my hair. “Look!” Sherlock exclaimed, leaning over the rail and pointing toward the darkness of the water. “Isn’t it awesome?”

I leaned over and glanced toward the sea. Sherlock was right—it was awesome. The waves lapping gently against the *Endeavor II*’s hull were outlined in a pale, yellow-green light. The phosphorescent glow faded quickly into darkness as each wave receded. As the next wave splashed against the hull, the crest lit up again with the eerie, green light. I had never seen anything like it. “Sherlock, it’s beautiful! What did you call it? Bio—”

“Bioluminescence,” he said softly. “The light is caused by millions of tiny organisms that emit a chemical light when disturbed. The light is similar in constitution to the light from a glowstick—”

“Skip the scientific explanation,” I told him. “Just enjoy the light.”

“Look, Penny, there’s a shark!”

I looked in the direction that Sherlock pointed, and sure enough, a dark fin sliced through the water, the ripples on each

side outlined in soft, phosphorescent light against the darkness of the sea. I shivered at the sight. “Let’s go inside, Sherlock.”

The deck swayed at that moment and the rail dropped toward the sea as the starboard side of the ship dropped into the trough between two breakers. Caught off balance, I fell forward against the rail, clutched frantically at it, and found myself tumbling right over it into the darkness of the ocean! “Sherlock!” I managed to scream before I hit the water.

To my surprise, the water wasn’t cold. It didn’t even feel wet. But as I plunged beneath the surf, I was surrounded by millions of glowing bubbles of yellow-green light from the bioluminescence in the water. I struggled for the surface and gasped for air. “Help!”

Hearing a loud swishing sound, I turned my head. My heart pounded with terror. The triangular fin of the shark was slicing through the darkness of the water, outlined in the yellow-green glow! “Sherlock! Help me! The shark is after me!” I thrashed frantically, and as I splashed, the water around me glowed brighter and brighter. “Sherlock! Help me!”

I felt a crushing pressure on my shoulder. The shark had me in its jaws. Terrified, I tried to pull away. There was no pain, just a crushing pressure. “Penny!”

I thrashed harder. “Sherlock! Help me! The shark’s got me!”

“Penny! Wake up!” I heard a giggle, but my terrified brain refused to register the sound.

The shark shook me harder and harder. It began to pull me beneath the surface of the water. I struggled against it, fighting for my life.

“Penny! Wake up! It’s just a bad dream!”

I threw my head back and gasped for air. The shark disappeared, and Lisa’s face floated in the dim light beside my pillow. “Penny, are you all right? You were dreaming.”

I rubbed my eyes and then looked hesitantly around the room. “Where’s Sherlock?”

Lisa giggled. “He’s probably in bed, silly. You were dreaming. Something about sharks and bio—bio—”

“Bioluminescence,” I said sleepily. “Good night, Lisa. Sorry I woke you up.” I lay back down and closed my eyes, still thinking about sharks and wondering where I had learned

the word *bioluminescence*. Within moments I was asleep again, dreaming about glowing green sharks driving flashy red Jaguars.

The *Endeavor II* passed through the Strait of Gibraltar sometime during the night, so we didn’t even get to see the Rock of Gibraltar. We awoke the next morning to learn that the ship was on a northerly course just a few miles off the coast of Portugal. We ate breakfast without Captain Stevens being present at the table. Just about the time we finished the meal, the ship’s engines slowed, and then came to a stop.

We hurried downstairs and out onto the main deck. Sherlock gave a low whistle. “Would you look at that!”

Two huge gray U.S. Navy cruisers rode at anchor less than a mile from us, and a smaller ship that looked similar to ours was just a few hundred yards away. Sherlock whipped out a pair of binoculars and studied the various ships. While we watched, a large military helicopter lifted off from the deck of one of the Navy ships and cruised toward us. Moments later, the clumsy-looking aircraft hovered over our stern deck just forward of the A-frame crane. As the twin rotors beat the air with a loud whup-whup-whup, a cargo door opened in the

bottom of the helicopter fuselage and a pallet wrapped in a cargo net was winched down to our deck. Two crewmembers raced forward and released the cargo net from the cable.

The helicopter rose straight up in the air and the cable quickly disappeared inside the door like a kid slurping in a long strand of spaghetti. As we continued to watch, the helicopter dropped toward the ship again and began to hover less than a foot above the helipad atop the aft control station. A door in the side opened, and six men in military uniforms leaped out and hurried down the steps to the 02 deck. I noticed that each was carrying a medium-sized duffel bag, as if they were planning to stay awhile.

The men disappeared through a doorway. Moments later they reappeared on the main deck and strode right past us without even glancing in our direction. All six of them acted as if they were really impressed with their own importance. Setting their duffel bags on the afterdeck, they hurried into the *Odyssey's* hangar.

Apparently unnoticed by the crew, Sherlock slipped forward and scanned the pallet on the afterdeck for several seconds. He hurried back to me with an excited look on his

thin face. “You won’t believe what’s happening, Penny,” he whispered. “Unless I’m mistaken, the United States has lost a nuclear weapon at sea, and the *Odyssey* is going to help hunt for it!”

“Yeah, right,” I told him.

“I’m serious!” he insisted. “The *Odyssey* is going to hunt for a nuclear weapon! That’s why we left the Mediterranean in such a hurry.”

Glancing down toward the net-shrouded pallet on the afterdeck, I suddenly had the funny feeling that my detective friend was right. If so, this could turn out to be quite an adventure.

Chapter 5 – Top Secret Mission

Captain Stevens and Chief Mate Webster hurried across the main deck to where the six military men stood looking over the pallet of equipment that the helicopter had off-loaded. The men started shaking hands as introductions were made. “Come on, let’s go up to the 02 deck,” Sherlock whispered to me. “We can get close enough to hear what they’re saying.”

We dashed across the deck and up two flights of stairs. “Five Air Force men,” Sherlock told me breathlessly as we ran. “One colonel, two majors, and two lieutenants. The sixth man is an Army lieutenant.”

“How do you know all that?” I puffed, trying to keep up. Even though he’s shorter than I am, he moves faster.

“Uniforms, Penny, uniforms.”

“Oh.” *You should have thought of that*, I told myself.

We came out on the 02 deck, starboard side. Sherlock paused just before we reached the aft control station and motioned for me to keep quiet. I nodded as we walked quietly to the railing. The open door of the *Odyssey*’s hangar was just below us, with the captain, chief mate and the six military men standing just a few feet away. Sherlock pulled me back from the railing so the men wouldn’t look up and see us. He held a finger to his lips.

“...accommodations on the 03 level,” Captain Stevens was saying. “We’ll put you two to a stateroom, with two staterooms sharing lavatory facilities.”

“I can’t share a stateroom with another person,” a hoarse voice said, and I peeked over the edge to see the speaker. The man was tall, rail-thin, and had wire-rimmed glasses.

“That’s the Army lieutenant,” Sherlock whispered in my ear as he pulled me back from the edge. “He’s an ordnance specialist.”

“What’s ‘ordnance’?” I asked.

“Weapons,” Sherlock replied.

“I must have a stateroom of my own,” the thin lieutenant insisted again. His voice was weird, kind of hoarse, with a hollow sound to it. It reminded me of a little kid trying to talk in a deep voice like a man.

One of the Air Force men laughed derisively. “Too good to bunk with Air Force personnel, lieutenant?”

“It isn’t that, sir,” the lieutenant protested. “It’s just that... well, I have extremely sensitive allergies. Tobacco smoke does me in.” He coughed nervously.

“None of these officers smoke, sir,” a second voice cut in.

And then the lieutenant’s hoarse voice. “Toiletries are just as bad, Major. Aerosol deodorants, after shaves—they all set me off.” Sherlock turned to me with a really strange look on his face. I wished I could have told what he was thinking at that moment.

“It’s not a problem, Major,” Captain Stevens said. “We can give the lieutenant his own stateroom.”

I glanced at Sherlock again. He was frowning, and I could tell he was deep in thought. I nudged him with my

elbow. “Whatcha thinking about?” But he just shook his head and didn’t answer.

“Captain,” another voice said, “please have a crewmember take our effects to our staterooms, if you would. I’d like to get this project underway as soon as possible.”

“Very well, Colonel,” Captain Stevens replied. “I’ll have our steward take your bags to the staterooms.”

“How quickly can you have the submersible in the water?” the colonel asked.

“Sir, we can launch the *Odyssey* in forty-five minutes, if we start immediately.”

“Immediately is exactly what I had in mind, Captain.”

Two frogmen in black wetsuits swam back to the *Endeavor II* as the *Odyssey* sank from sight beneath the choppy waters of the Atlantic. Machinery began to hum, and the huge A-frame crane slowly raised back to a vertical position. The divers climbed a ladder on the ship’s fantail and scrambled aboard, dripping water all over the deck.

It had been fun watching the *Odyssey* launch. A crewmember had pulled a steel cable from a winch mounted at the very stern and fastened it to the cradle in which the *Odyssey* rested inside the hangar. When the winch tightened the cable, the *Odyssey* had rolled out on deck, following the little train tracks. Once the minisub was in position beneath the A-frame crane, cables were attached to several lift points on the top of the sub, and the craft was lifted into the air. The crane swung slowly out over the fantail, dropping the *Odyssey* gently into the water as easily as a child putting a rubber duck into the bathtub.

Once the minisub was fully submerged, Hawkins and the six military men left the afterdeck. I suppose they were either going to work stations or to check out their staterooms. Sherlock and I had watched the launch from the aft section of the 02 deck. Just a minute or two later Hawkins strolled up and stood at the rail with us. “It’s somethin’, isn’t it, watchin’ that little sub take off on her own,” he said with a faraway look in his eyes. “I never get tired of seein’ it.”

The *Odyssey* stayed down for a little over six hours without finding whatever it was they were looking for. Lisa and I spent a good part of the afternoon in the library again, while Sherlock spent most of it in the computer lab with Mr. Diamond. It was just after five o’clock when Sherlock came hurrying into the library. “The *Odyssey*’s coming back in,” he told us. “Want to go watch them retrieve her?”

The retrieval process was just about the reverse of the minisub’s launch. When the *Odyssey* bobbed to the surface, two divers swam out and attached the lift cables. The A-frame crane, which was extended out over the water, slowly rose to a vertical position, lifting the *Odyssey* from the sea. The minisub hung suspended between the uprights of the crane like a swing hanging from a swingset. The crane lowered the *Odyssey* to rest in place in its cradle, which was then winched back into the hangar. As the minisub entered the hangar, a hatch popped open at the top of the vessel and a man’s head appeared. The five Air Force officers and the Army lieutenant swarmed toward the sub to confer with the pilot.

Sherlock turned away in disappointment. “I wanted to talk with the pilot,” he said, “but we’ll just be in the way. Let’s head to the mess deck for supper.”

The mess attendant was serving our table when the six officers strode into the dining saloon. Captain Stevens hurried over to them and led them to our table. To my surprise, he took the time to introduce Mr. Diamond, Lisa, Sherlock and me to the officers. The five Air Force men were Colonel Jack Andersen, Majors Jim Powell and Ward Smith, and Lieutenants Lance Holloway and Frank Thompson. The thin Army officer was Lieutenant Terry Owens. Once the six were seated, every seat at the captain’s table was filled.

Captain Stevens had already led in prayer before the military men arrived. I noticed that all six men simply started eating when they got their food. Not one of them stopped and thanked God for it. They all seemed to be self-made men, and I guess they thought that they didn’t need to be thankful to God for anything.

Lieutenant Owens was seated across from me, and I studied him as I ate. I had never before seen a person so incredibly thin. Owens was a scarecrow of a figure, nearly six

feet tall with narrow shoulders, bony arms, and the tiniest hands I have ever seen on a man. He wore thick glasses, but I noticed that his eyes darted nervously about as he ate.

As I watched Owens and the other officers, I thought of what Sherlock had told us about searching for a missing nuclear weapon. *Now, how would he know that?* I asked myself. *There’s no way! He was just making that up!* I took a bite of broccoli with cheese sauce. *Well, there’s one way to check out Sherlock’s story,* I told myself. *Ask these officers!*

It was a wild, crazy idea, and I acted before I had time to think it through. Before I knew what I was doing, I found myself addressing Colonel Andersen. “Sir,” I croaked, “Sherlock says that the *Odyssey* is searching for a nuclear weapon that was lost at sea. Is that true?”

You should have seen the effect my question had on the six officers! Major Powell was taking a long drink of cranberry juice when I popped the question, and he reacted by coughing so violently that cranberry juice sprayed across the table, drenching the two officers across from him. Owens dropped his fork. It clattered to his plate, bounced off, and fell to the floor. The colonel

choked on a piece of meat, and one of the majors started slapping him on the back.

Once the colonel was out of danger, there was dead silence at our table. The six officers sat glaring at me. I wouldn't have gotten this much reaction if I had announced that I was planning to assassinate the President.

“Young lady—”

Lieutenant Holloway started to speak, but Colonel Andersen cut him off with an authoritative wave of the hand. “I'll handle this, Lieutenant.”

He turned to me. “Young lady,” he said sternly, “who told you this?”

My chest constricted with fear under the force of his withering gaze. “S-Sherlock d-did,” I stammered.

“And who is Sherlock?”

Sherlock timidly raised his hand. “I am, sir.”

The colonel stared at him. “You, eh? Son, just how much do you know—” He stopped in mid-sentence and looked at Captain Stevens. “Is there some place we can go to talk? Some place private?”

The captain pointed with his thumb. “The library. It's right next door. We can shut the door.” The two officers started wiping cranberry juice from their uniforms with their napkins. Owens retrieved his fork from the floor and placed it on his plate. The officers were still glaring at me like a bunch of angry bulls.

Colonel Andersen stood to his feet. “I want everyone at this table to go to the library immediately,” he said in a quiet voice. At the other tables the crew and scientists looked up in surprise as the twelve of us filed silently from the dining saloon. The room suddenly got deathly quiet, and then, buzzed loudly with an outburst of conversation once we were outside the door. Everyone seemed to be talking at the same time.

Once inside the library, the colonel had Sherlock and me take seats side by side. The officers gathered around us as the angry colonel confronted Sherlock. “Just how much do you know about this operation, young man?” the colonel asked. He was right in Sherlock's face.

“N-not m-much, sir,” Sherlock stammered. He was so nervous that he was shaking like a second-grader in the

principal's office. I glanced over at Lisa, and she looked as if she were about to cry. I felt the same way.

The colonel turned on me. "And what do you know about this, young lady?"

I felt like a hapless mouse pinned under the paw of a hungry cat. "N-nothing, s-sir," I stammered. "J-just what S-Sherlock told me."

"Who else have you been talking with?"

"N-nobody, sir."

"Just your friend Sherlock."

"Yes, sir."

"And he's the one who told you that there was there was a nuclear weapon missing?"

"Y-yes, sir." I took a deep breath, which came as a sobbing sort of gasp. "H-he told me."

The colonel turned on Sherlock. "Well, young man," the officer snapped, "suppose *you* tell me just what you know about all this."

"A-all I know is th-that the Air Force has lost a plane, that a nuclear bomb or missile is missing, and that we're searching for it," Sherlock replied. "Th-that's all."

The colonel glanced at the other officers, looked at Captain Stevens, and then back to Sherlock. "Anything else?"

"No sir, not yet."

"Not yet!" Colonel Andersen was exasperated. "Son, where are you getting your information?"

"I just put two and two together, sir." Sherlock was starting to calm down just a bit.

"Who have you been talking to? Where are you getting your information?" The colonel was not calming down.

"Nowhere, sir," Sherlock replied.

"Who told you that we lost a plane? Who gave you the idea that we were searching for a nuclear weapon?"

"No one, sir. I just figured it out."

"Don't give me that, kid. Now, I'm going to ask again—WHO HAVE YOU BEEN TALKING TO?"

"No one, sir. As I tried to tell you, I just made some observations and arrived at my own conclusions."

The colonel frowned. "That's impossible. This mission is top-secret." He glanced at Captain Stevens. "We should have been informed that there were civilians aboard

before the *Endeavor II* even came on site.” Captain Stevens flinched.

“But I did figure it out, sir,” Sherlock protested. “I’m telling you the truth. As the *Endeavor II* arrived on the scene earlier today, I observed that the *Atlantis* had an underwater observation sled on her afterdeck. The sled was rigged with high intensity lights and sonar locators, which told me that they were searching for something. The fact that the five of you were Air Force rather than Navy told me that a plane was involved, and the fact that Lieutenant Owens is an ordnance specialist told me that we were searching for a weapon.”

“What gives you the idea that we’re looking for a nuclear weapon?” the colonel demanded. He looked worried, as if he were trying to decide whether or not to believe Sherlock’s story.

Sherlock shrugged. “The military wouldn’t be making this much effort to retrieve the weapon if it were conventional, rather than nuclear, would they? And when the helicopter drop-loaded a pallet on the *Endeavor II*’s afterdeck, I checked it out. I found radiation detectors, protective suits—all this

equipment that said ‘nuclear disaster’. What else was I supposed to think?”

I had thought that my ordeal was finished, but the colonel turned on me a second time. “What else do *you* know about it, Missy?”

Why do adults always call me that? I hate it when they do. “N-nothing sir,” I managed to croak. “I-I mean, just what Sherlock told me. Th-that’s all.” I bit my lip to keep from crying.

“And you haven’t been talking to someone else? No one told you what’s going on?”

“N-no sir. Sherlock just figured it out.”

The colonel was silent for several minutes as he thought it over. I waited anxiously to see how he would respond. What if he had us thrown off the ship, or put us in protective custody or something? He was pretty upset with both Sherlock and me. I looked at Mr. Diamond for the first time, and he looked pretty anxious, too.

The colonel stepped closer to Sherlock and folded his arms across his chest. “Young man,” he said sternly, “interfering with a top-secret military operation is a serious

federal offense. If the right information gets into the wrong hands, it can jeopardize our national security. Do you understand me?"

Sherlock nodded nervously.

Colonel Andersen turned and pointed out the library windows, which afforded us an excellent view of the sea. "If you'll look closely, you'll see two vessels from an antagonistic Middle East country." We all turned and stared out the windows. Sure enough, I could see two ships several miles away. They were hardly more than dots on the horizon and I hadn't even noticed them before. "Those vessels are loaded to the gunwales with listening devices and electronic spy gear," the colonel continued. "Those captains would give their eye teeth to find out what's happening here, and if they did, they could use it as propaganda against the United States and create trouble with some of our Islamic allies. Do you understand the seriousness of what we're involved in?"

Sherlock nodded again.

Colonel Andersen suddenly grinned. "How would you like a job at the Pentagon?"

Sherlock blinked in surprise. "Sir?"

The colonel laughed. I let out a sigh of relief. Everything was going to be all right. "I'm just kidding of course, Sherlock. But you're an unusual young man. I'm going to do something unusual. We'll have to keep you and your friends aboard ship until our mission is resolved and this incident is closed, but I'm going to tell you exactly what is going on in exchange for a promise from you that you'll keep it to yourselves." He glanced at the two ship's officers, then at Mr. Diamond, Lisa, Sherlock and me. "Not a word of what I tell you leaves this room. Understood?"

We nodded.

The colonel looked at Captain Stevens. "Captain, inform your communications officer that absolutely no communications of any form leave this ship without my approval. That applies even to your communications with the Atlantic Oceanic Institute."

Captain Stevens nodded. "Yes, sir."

The colonel turned back to us. "Here's the situation. Almost three weeks ago, a KC-135 StratoTanker was refueling a B-52 StratoFortress at an approximate altitude of 35,000 feet.

There was an explosion, and both aircraft were destroyed. Most unfortunately, we lost nine good men in the accident.”

“This sounds just like the Broken Arrow incident off the coast of Spain in 1961,”

Sherlock remarked.

The colonel stared at him. “How do you know about that?”

“I read about it, sir.”

Colonel Andersen paused and looked around the room. I think he was trying to read the reactions of the other officers. “The B-52 was carrying eight nuclear weapons,” he continued. “We recovered seven of them: five on land and two in very shallow waters. The eighth is still missing.”

“Are we talking about a missile or a free-fall bomb?” Captain Stevens asked.

The colonel shook his head. “I’m sorry, Captain, but that’s classified information.”

Sherlock spoke up. “But even I could answer that, Colonel.”

The officer laughed. “How would you know that, Sherlock?”

“The B-52G and the B-52H were both modified to carry twelve missiles or eight free-fall bombs, sir,” Sherlock replied. “Since you told us that eight nuclear weapons were aboard the StratoFortress, the logical conclusion is that we’re talking about bombs, rather than missiles.”

The colonel was stunned. “Is there anything you don’t know?” he asked incredulously. He looked around the room. “I might as well tell you the rest of the story,” he said, “before Paul Harvey here does it for me. Our computers have used the locations of the seven recovered bombs to plot trajectories and determine the exact location of the StratoFortress when the explosion took place. The computers then plotted three different trajectories for the missing bomb: one if the chute opened properly, a second if it did not open, and a third if the weapon came apart. Those three sectors are code-named Alfa, Bravo, and Charlie respectively. The mission of the *Odyssey* is to search the Alfa sector, which is where we expect to find the bomb if the chute did open.”

“Why is it so important to find the bomb,” Lisa asked, “if it’s in the ocean? Is there a chance it could go off?”

The colonel shook his head. “A nuclear bomb cannot go off by accident,” he told us, “even if it fell on land. It can only go off if it is properly armed, which takes a special sequence of commands. There are dozens of safeguards to prevent an accidental nuclear explosion.”

“Then why not leave it where it is?” Lisa argued. “It’s in pretty deep water, isn’t it?”

The colonel shook his head again. “We’re approximately six miles from land, and the water is just over half a mile deep here. But you saw the two ships just a few miles from here. We have reason to believe that they are aware of our predicament. Were they to retrieve the bomb, they could access some of our most critical technology. And even if they couldn’t recover it, they can use it as a propaganda tool in the international community if we don’t recover it. The bomb must be retrieved at all costs.”

Colonel Andersen stood to his feet, and the other officers immediately did the same. “This discussion has gone far enough tonight,” the colonel said. “But remember, not a word of this goes beyond this room.”

My mind was racing as we filed silently back to the dining saloon. Imagine being in on an adventure of international importance! If the U.S. didn’t find the missing bomb, there was no telling what could happen!

The officers sat stony-faced through the rest of the meal, and I felt that they were watching Sherlock and me. Nobody said a word. My hand trembled every time I raised my fork to my mouth, and my mouth was dry. I’ve never been so nervous in all my life. My food tasted like sawdust. Finally, the meal was over, and Lisa, Sherlock and I escaped into the freedom of the night air.

I took a deep breath and let it out slowly. “Now I know how Daniel felt when he was first tossed into the den of lions,” I remarked, trying to sound cheerful and nonchalant. “I thought the colonel and the others were going to eat us alive!”

Sherlock didn’t say anything. He headed for the stern of the *Endeavor II*, so Lisa and I tagged along. We climbed the stairs to the 02 Level.

“Imagine being in on a search for a missing nuclear bomb!” I exulted. “Unless they kick us off the ship, we’ll get to see the whole thing!”

Sherlock was silent. I looked at him. Twin beams of moonlight reflected off his glasses, making me think of a car's headlights. I couldn't see his eyes. "But don't you think it's exciting?" I prodded. "I think this whole thing is awesome!"

"Penny." His voice was soft, hardly more than a whisper. "The colonel wasn't telling us the truth. I don't believe that story about the accident involving a B-52 StratoFortress and a KC-135 StratoTanker. He was making the whole thing up!"

I was disappointed. "So the U.S. hasn't lost a nuclear weapon at sea? Then what exactly are we searching for?"

"There has been some kind of a nuclear incident," Sherlock replied quietly. "I'm just not sure what. But the colonel's account is not what happened; he was giving us a cover story to keep us quiet."

"How do you know?" Lisa asked.

"A nuclear bomb would have a locator transponder," Sherlock replied. "That business about plotting trajectories was the way it was done in 1961, but not today. A transponder would allow us to home right in on a nuclear bomb."

"Suppose it had one that wasn't working," I suggested.

"Not likely," he replied. "They're pretty reliable."

"So you think it's something else?"

"Did you watch the Colonel Andersen's face as he was telling us his story?" Sherlock queried. "You could tell he wasn't telling the truth. The way he kept watching Mr. Diamond and me to see if we were buying it told me immediately that he was lying to me. And the way he kept glancing at the other officers as if for reinforcement—that confirmed it. The colonel lied to us."

"You acted as if you believed him," Lisa argued.

"I don't want him to suspect that I'm not buying his story," Sherlock replied. "I think we'll have more of a chance of discovering the truth."

"Do you think they'll kick us off the ship?" I asked. "If they're not telling us the truth and they have something to hide, wouldn't that be the safest way for them?"

We found ourselves right beside the aft control station. Sherlock leaned over the rail and stared down at the A-frame crane. He shook his head. "I don't think so," he said slowly. "We're just a bunch of kids, and I don't think he's going to worry a whole lot about us. But Mr. Diamond is a different

story—he’s a wealthy, powerful businessman with a lot of connections. Did you see the way Colonel Andersen kept watching him? He wanted desperately for Mr. Diamond to swallow the story about the accident.”

“So you think he’ll send Daddy home?” Lisa asked. She sounded worried.

“No, I don’t think so. Put yourself in the colonel’s place—if you wanted to keep a man quiet, what better way than to isolate him from the rest of the world aboard a ship? If you send him home, he’s free to share anything he knows. I could be wrong, but I think they’ll keep us all here until the entire episode is finalized.”

“You sound as if you think there’s something illegal going on here,” I observed.

“Oh, no, I didn’t say that,” Sherlock protested hastily. “But Colonel Andersen wants to keep us in the dark, and that’s why he fabricated that story about the refueling accident.”

“So what do we do now?” I worried.

“Nothing,” Sherlock replied. “We keep quiet and just try to stay out of their way. This really is none of our concern.”

I wasn’t buying that. I knew Sherlock too well. I’m sure that he was sincere, but I knew it wouldn’t turn out that way. Based on our past experiences, I knew that it would be no time at all until he and I were right in the middle of things. And that usually led to trouble.

We were at breakfast the next morning when the fire alarm went off with an ear-splitting howl. Captain Stevens leaped to his feet with an expression of concern on his usually cheerful face. “This is not a drill,” he said quietly.

A voice came over the squawk box, which is the crew’s terminology for the intercom system. “All available personnel to the main deck hangar,” the voice announced. “The minisub is on fire! I repeat, the *Odyssey* is on fire!”

Chapter 6 – Sabotage

The dining saloon emptied as military officers, crewmembers, and scientific personnel raced down to the main deck. The entire group of us rushed into the minisub's hangar to find smoke pouring from the bottom of the *Odyssey's* hull. Hawkins and Summers were working frantically with power wrenches to open the sub's battery bays. A large, red fire extinguisher lay at their feet, ready for use.

“We've just about got it open!” Hawkins yelled.

“Someone get the fire extinguisher ready!”

One of the scientists snatched the extinguisher, pulled the pin, and stood ready. Hawkins and Summers leaped clear as a large panel fell away from the bottom of the sub. Smoke billowed out, filling the hangar. “Douse it!” Summers screamed.

White foam streamed from the extinguisher as the scientist leaped into action. The man pivoted back and forth, spraying the battery compartment in rapid motions. Captain Stevens appeared with a second extinguisher and helped battle the flames. In mere seconds, the blaze was extinguished.

Coughing and choking, the crowd of spectators streamed from the hangar and rushed to the fantail for cleaner air. Someone turned on the two giant fans inside the hangar, and the cloud of smoke billowed from the open hangar door and dissipated into the air above the afterdeck. Captain Stevens, Hawkins and Summers appeared in the middle of the smoke and hurried to the fantail with the fire extinguishers still in hand.

“What happened?” a voice in the crowd demanded. All eyes jumped to Captain Stevens.

“Apparently the battery bank overheated and caught fire,” Captain Stevens replied. “Perhaps the batteries overcharged.”

“That's not possible,” Hawkins declared. “The *Odyssey's* charging system has built-in safeguards to prevent just that.”

Captain Stevens shrugged. “That’s exactly what I thought.”

“How much damage to the sub?” another crewmember asked.

“There’s no way to know yet,” the captain replied. “We’ll check it out just as soon as the smoke clears.”

Colonel Andersen stood staring into the hangar as if he were in a trance. “Well, there goes a day’s diving,” he said disgustedly. “At best.”

We all stood talking in quiet tones as we waited for the smoke to clear. Everyone was keenly aware of what the fire meant to the sub’s diving schedule, but only those few who were aware of the *Odyssey*’s mission to find the missing nuclear bomb understood the full significance of what had just happened. The delay could be costly to the United States.

Finally the smoke had cleared enough to allow us to reenter the hangar. “No one is allowed inside the hangar except Hawkins, the engineering crew and the electrical crew, and myself until we have a chance to check this out,” Captain Stevens ordered. “The hangar is off limits to all other

personnel.” My heart sank. I was hoping to find out what had caused the fire!

But at that moment Sherlock stepped from the door of the hangar with an electrical instrument in his hand. He had been inside the hangar, and we hadn’t even missed him! “Captain, the polarity was reversed on the *Odyssey*’s charging system,” he reported. “I just put a multi-meter on the cable, and like I said, someone has reversed the polarity!”

Captain Stevens frowned. “How could that be?”

Sherlock’s face took on a serious look. “It was done deliberately, sir. Someone switched the two wires. The batteries shorted out, overheated, and caught fire.”

Hawkins shook his head. “That’s impossible, Captain. The charging system has a protective circuit to prevent such a possibility.”

Sherlock handed him the multi-meter, which is a device for checking electrical circuits. “Check it, sir.”

The men walked inside the hangar, but Sherlock hesitated at the door. Captain Stevens noticed. “Come on in, Son,” he said kindly. “You’re in on this, too.” My heart was

in my throat as I slipped in, too, hoping the captain wouldn't kick me out.

The charging cable lay on the deck, disconnected from the minisub's charging connection. Hawkins stuck two little leads from the multi-meter into the end of the charging cable. He frowned, pulled the leads back out, and reinserted them again, watching the digital display on the multi-meter as he did. "The kid's right," he said finally. "But how could that be possible?"

He stepped over to the charging unit against the bulkhead. "Summers, help me get the front off this thing," he said. The men used power screwdrivers to remove the sheet metal panel on the front of the charger. Once the front was removed, Summers reached inside, grabbed a handle, and pulled. To my surprise, a drawer-like tray slid out from the front of the charging machine. The tray was filled with wires and electrical circuits, almost like the inside of a computer. Both men knelt and began to examine the components.

"Here's the protective circuit that I mentioned, sir," Hawkins said to Captain Stevens as he pointed to one particular area in the tray. "It looks like the circuit is still intact."

Sherlock leaned over them. "Look at this," he said, pointing. "Someone has by-passed the circuit! Unless I'm mistaken, this wire shouldn't be here!"

Captain Stevens knelt beside the two men and leaned close. "The kid's right, Captain!" Summers exclaimed. "And that means just one thing. This was a deliberate act of sabotage!"

The fire was the only topic of discussion at lunch that day. As it turned out, the damage to the *Odyssey* was minimal. The blaze had destroyed both of the high-capacity, thousand-pound batteries in the compartment amidships and burned the insulation completely off the electrical cables inside the compartment. But the battery in the bow compartment had apparently escaped any damage, and, other than some unsightly black smudges on the inside of the battery compartment amidships, the *Odyssey* itself was undamaged.

We learned that there was a back-up set of batteries in a storage compartment in the hangar, kept fully charged at all times. As we ate lunch, the sub's technicians were installing

the new batteries and checking the sub's electrical systems. Captain Stevens was promising that the *Odyssey* would actually make a four-hour dive that evening, but the military officers were not convinced that it would be possible.

"Sabotage," was the one word on everyone's lips. No one could deny that the fire was a deliberate act of sabotage intended to keep the *Odyssey* from diving. Captain Stevens had tried to keep the matter quiet, but it seemed that everyone aboard knew every detail right down to the reversed wires in the charger and the fact that it was Sherlock who had discovered the vandalism. No one had any ideas as to *who* could have caused the damage, but a few of us knew *why*.

Captain Stevens had ordered that the *Odyssey's* hangar be secured whenever it was to be left unattended, and that he, Chief Mate Webster and Colonel Andersen would be the only ones with Ving cards to the hangar door. Any technicians needing access to the hangar would have to go through one of those three men, and a record was to be kept of the names of anyone requiring access. The captain wasn't taking any chances on an act of sabotage happening again.

To the surprise of nearly everyone aboard the *Endeavor II*, the *Odyssey* did dive late that afternoon. Her technicians had worked fast and furiously, installing the new battery banks and electrical cables and thoroughly checking the minisub's electrical and charging systems. The saboteur's work in the charging unit itself was corrected.

The setting sun was casting long, golden paths across the sea as Lisa and I stood on the aft part of the 02 deck, watching the *Odyssey* return to the ship. As far as we knew, the minisub was returning without finding anything, but it was reassuring to know that the little craft was operable again. Lisa turned to me as the men were securing the hangar door. "I'm heading down to our room," she told me.

I yawned. "I think I'll run down to the main deck and see if Sherlock and your dad are in the computer lab."

"See you in a little bit, then," she said. She turned away and headed across the deck.

I watched the sunset for a moment or two longer and then hurried across the deck and downstairs toward the computer lab to check on Sherlock. The stairwell on the main

deck was dark, and as I stepped off the bottom step, I ran smack into a man coming up. We actually banged into each other. I gave a little cry of alarm and jumped back, tripping on the bottom step and falling backwards onto the stairs.

“Many pardons, please, Miss,” the man said in a foreign accent. He leaned forward and grasped my wrist, pulling me to my feet. As he did, his lightweight jacket swung open and I saw that he was carrying a large, nickel-plated handgun in a shoulder holster.

Alarmed, I stared up into the man’s face. To my astonishment, he was the man from the plane! The Iranian. I jerked open the stairway door and fled in panic.

Chapter 7 – Chess Tournament

“OK, Penny, calm down,” Mr. Diamond told me for the fourth time. “Everything’s going to be all right.”

I struggled to catch my breath. My heart was still racing, and I realized that my hands were still shaking. I did feel a little calmer, though, in the safety of the computer lab. “But it’s him!” I protested. “The man from the plane! The Iranian! He followed us here!”

Mr. Diamond smiled gently. “I don’t think so, Penny. I think your imagination is working overtime.”

“But it’s him!” I protested. “I know it is! I’d recognize him anywhere!”

“Describe him,” Sherlock requested.

I took a deep breath and held one hand over my pounding heart. “I’m not sure I can. I only saw him for a second or two.”

“But you said you saw him on the plane.”

“Oh, yeah.” I tried to think. “He was, uh, dark-skinned. I think he was Iranian or something.”

“Iranian?”

“Yeah, you know, from one of those Middle East countries.”

“What was he wearing?” Mr. Diamond asked.

I shrugged. “I’m not sure. But I do know that he had on a light-weight jacket.”

“So do most of the personnel on this ship, if they’ve been out on deck,” Sherlock pointed out. “It’s almost November, remember?”

“How tall was he?” Mr. Diamond asked.

“I’m not sure,” I replied. “He was leaning over me, and again, I only saw him for a second or two.”

“But you saw him on the plane,” Mr. Diamond told me.

“Yes, but he was sitting down both times.”

Sherlock was a bit frustrated. “Penny, can’t you tell us anything more about him?”

I thought for a moment. “He was incredibly strong,” I said slowly. “When he grabbed me by the wrist, I remember thinking how incredibly strong he was. Oh, and he had a gun.”

“You already mentioned that. Revolver or automatic?”

I thought for a moment. “I don’t think it was a revolver, so it must have been an automatic. And it was real shiny, you know, nickel-plated.”

“Well, if you think of anything else, Penny, be sure to mention it. You haven’t given us much to go on.”

A sudden idea hit me like a torpedo. “I know who he is! He’s the one who sabotaged the *Odyssey*!”

Sherlock shook his head. “That’s just a guess, Penny. There’s nothing to indicate that he was the one responsible.”

“He’s from a Middle East country, isn’t he? Remember what Colonel Andersen said? Those two ships were from an antagonistic country in the Middle East!” I looked from Sherlock to Mr. Diamond. “Doesn’t that make sense? The Iranian’s the one who sabotaged the *Odyssey*!”

Lisa was in her bunk when I walked into our stateroom. I started to tell her that the mystery man from the airplane was now aboard the *Endeavor II*, but I saw that she was reading her Bible. A feeling of guilt stabbed at my heart. I hadn’t picked

up my Bible since we left home Monday night. As a matter of fact, it was still in my suitcase; I hadn't even unpacked it. I let out a sigh, realizing that in the last few weeks, I hadn't been faithful at all in my prayer life or Bible reading. I had been too busy to spend much time with the Lord.

Trying not to think about my careless devotional life, I threw myself across my bunk and stared out my porthole at the moonlit sea. I guess I drifted off to sleep.

"Now hear this!" Captain Stevens's voice blared from the squawk box in the passageway outside our stateroom. "The chess tournament starts at 2100 hours in the lounge! We have nineteen entrants, and we really could use five more. Come on up and join in the fun!"

I rolled over and looked at my watch. Quarter till nine. The tournament would start in fifteen minutes. "You gonna go?" Lisa asked.

"I suppose so," I replied. "Give me time to brush my teeth and we'll walk up together."

"I wonder if Sherlock will enter," Lisa mused. "Captain Stevens said that they need five more entrants."

I shook my head. "Sherlock doesn't play chess," I told her. "He says he doesn't have the patience for it."

"But just think what he could do with that brain of his," she continued. "He'd probably win the tournament."

I laughed. "Probably. But I don't think you'll talk him into it."

When we entered the lounge we saw to our surprise that Sherlock was seated across a chessboard from one of the Air Force majors. "I thought you didn't play chess," I teased.

Sherlock shrugged. "Major Thompson insists that he's going to teach me." The major began explaining the rules of the game to the young detective, so Lisa and I took seats on a sofa near the door. The lounge is a pleasant room with several small tables, each surrounded by four comfortable chairs. A number of chess boards and timers were set up at the tables, ready for the battles of wits that were about to take place. The room was crowded and stuffy. People were chattering excitedly, as if they were about to witness a very important event.

Captain Stevens stood to his feet and called for attention. “Welcome to the *Endeavor II*’s first annual chess tournament,” he said loudly. He paused and the room grew quiet. “You’ll be pleased to know that five additional players have signed up, giving us an even twenty-four players, which is ideal for this tournament. The new players are Larry Diamond, Lieutenant Terry Owens, Major Ward Smith, Colonel Jack Andersen, and our youngest entrant, Sherlock Jones. Sherlock is just learning the game of chess tonight, but he signed up for the tournament anyway.” He smiled in Sherlock’s direction. “Don’t be disappointed, Son, if you don’t win any games. I’m sure that this will be a learning experience for you, and it will get you started with the mind-challenging game of chess.”

He turned back to address the entire group. “We’ve divided the twenty-four players into four divisions of six players each. Check the rosters on the forward bulkhead to find which division you’re in. Divisions one and two will stay here in the lounge tonight; three and four will move to the dining saloon for more room. We’re playing double elimination—two losses and you’re out. Wins will be posted each night on the rosters so you can see how each player

stands. The winners from each of the four divisions will compete against each other for the title, probably four or five nights from now. Good luck to each of you. I’m in division three, so I’ll meet some of you in the dining saloon. Play starts in ten minutes.”

He grinned. “I must warn you—once I get behind a chessboard, I’m vicious. Don’t expect any mercy if you play me.” The crowd laughed, and a number of people headed for the dining saloon.

Lisa and I drifted from table to table, watching as the various games got under way. “Captain Stevens says that the tournament will provide a diversion and some relaxation for the crew and the scientists,” Lisa told me. “They’ve been on board the *Endeavor II* for over a month now.”

After watching the competition in the dining saloon for fifteen or twenty minutes, we slipped back to the lounge. Sherlock and Major Thompson were engaged in a game, but I noticed that Sherlock had fewer pieces left on the board than the major did. Sherlock looked frustrated and embarrassed. I felt sorry for him.

“Check,” Major Thompson said, and Sherlock groaned. Major Thompson smiled. “Don’t take it so hard, Son. This is your first game. It usually takes a new player several games just to learn the moves and begin to understand the strategy behind the game.”

Sherlock studied the board for several minutes and then moved a knight into position to protect his king. He let out a sigh of relief.

Moments later, though, Major Thompson had him in check again, and this time there was no escape. Sherlock had lost his first game. His opponent chuckled at the despondent look on Sherlock’s face. “It’s just a game, Son. You did very well for your first time.”

Sherlock nodded. “One more loss and I’m out of the tournament, though.”

The major nodded. “Most of these people are experienced players, Sherlock. Don’t take it too hard if you lose again tomorrow night.”

Sherlock shuffled over to the roster on the bulkhead and marked in a win for the major. His shoulders sagged despondently as he disappeared into the passageway outside

the lounge. I could tell that he hated to lose, and I felt sorry for him. At the time, I had no idea that the chess tournament was going to provide far more than just a diversion for the ship’s personnel.

The next morning at breakfast the chess tournament was the main topic of conversation. People were calling out to each other, jesting with the losers, and predicting who would win that night. I had never seen this group of people so animated. *They’re really getting into this*, I thought. I glanced across at Sherlock. He was unusually quiet.

“Did you win or lose?” I asked tall Lieutenant Owens, who was seated across from me at the table.

He looked at me as if the question was an affront to him. “I won, of course,” he answered in that hoarse voice of his. He stood to his feet and walked away.

I glanced over my shoulder to see where he had gone. He was leaning on the end of one of the other tables, talking with two crewmembers dressed in blue jumpsuits. “Who are

those two men that the lieutenant is talking to?" I asked Sherlock.

"Ed Rogers and Mark Wellington," Sherlock replied.

"They're the *Odyssey's* pilots."

I turned around and studied the two men with awe. "I'd love to have their job," I said. "Imagine being the pilot of a minisub!"

"You can't be claustrophobic," Sherlock replied.

"They don't have much working room inside the *Odyssey*." He turned to Chief Mate Webster, who was seated beside him.

"May I have the salt, please?"

I glanced back at the table where the *Odyssey's* pilots sat just in time to see Lieutenant Owens knock a glass of orange juice over with the side of his wrist. I wasn't sure, but it looked like he did it deliberately. As the orange juice splashed across the table, both pilots jumped to their feet to avoid getting soaked. The lieutenant leaned across the table in a quick movement and then reached out and picked up the tipped juice glass. I couldn't hear what he said, but it looked like he was apologizing to the two men. The mess attendant

appeared with towels to clean up the mess, and the incident was over. Lieutenant Owens returned to our table.

An hour after breakfast, Lisa and I stood on the aft section of the 02 deck, watching as the crew prepared the *Odyssey* for launching. They winched the minisub out of the hangar and into position beneath the A-frame crane, attached the lift cables, and then just left it there. I noticed that the entry hatch was still open. Several men stood around talking on the afterdeck, but nothing was happening. Ten minutes went by, and still no action.

"Why don't they close the hatch and launch the sub?" I asked.

Lisa shrugged. "Looks like they're waiting for something."

I took a deep breath of the cool sea air. "I think I'll head down to the library. Wanna come?"

She shook her head. "I'll stay here."

I walked into the library to find Sherlock at one of the desks along the bulkhead. His back was to me and I didn't think he had heard me come in, so I sneaked up behind him.

“Boo!” Then I saw that he had his Bible open on the desk.

“Ooh, sorry,” I said.

He turned around. “Hi, Penny.”

“Sorry to interrupt,” I said softly. “I didn’t realize that you were having your devotions.” I felt a stab of guilt since I hadn’t had mine.

“Oh, that’s OK,” he assured me. “I was just memorizing.”

“Memorizing?”

“Sure. What’s wrong with that? I’m working my way through the New Testament.”

I laughed. “I just thought that—well, with your photographic memory and all, you could just read it once and have it locked away in that computer brain of yours. I never thought you’d have to take the time to memorize.”

He shrugged. “That’s partly true, I suppose. But I want to be certain that I can identify any verse by the reference, and I want to make dead certain that I have it correct, since it’s God’s Word.”

I leaned over his shoulder and looked at his Bible. It was open to I Timothy. “You said that you’re working your

way through the New Testament,” I said. “Did you start in Matthew?”

He nodded.

“And you’re up to I Timothy?”

He nodded again.

“Sherlock, that’s incredible! That’s—” I stopped and counted on my fingers. “Sherlock, that’s fourteen whole books! And I Timothy will make fifteen!”

He shrugged. “God’s Word is important. It’s our manual for life.”

I looked at him with a new respect. “I can’t believe that anyone could memorize fourteen whole books! I sure wish I had a brain like yours!”

He looked at me with a strange expression in his eyes. “Maybe you can’t memorize as quickly as I, but it’s still important to do it, Penny.” *I haven’t even been reading lately, much less memorizing, I told myself. And here he is, memorizing his way through most of the New Testament!*

Sherlock pushed his Bible back and turned around to face me. “Did you hear what happened?”

“No, what?”

“Ed Rogers became violently ill just a short time ago,” he told me. “He and Wellington were preparing their instruments for the *Odyssey*’s dive this morning, and he became so sick he could hardly stand up. He’s in the sick bay on the 02 deck right now.”

“What happened? We just saw Rogers and Wellington at breakfast, remember? When Lieutenant Owens spilled the orange juice, they sure moved fast enough! They both looked fine to me.”

Sherlock frowned and nodded. “It does seem kinda strange, doesn’t it? According to what I heard, Rogers was feeling fine one moment, then came down with stomach cramps and nausea the next. There’s no way he can take the minisub down.”

“Will the *Odyssey* still dive today?” I asked.

Sherlock nodded. “Wellington can handle the sub, and two of the Air Force officers are going along as observers. They can’t afford to miss even a single day. The missing bomb must be found.”

“Hey, I’ll leave you to your memorizing,” I said.

“Catch you later.” As I left the library, I wasn’t thinking about

the sub or the missing nuclear bomb, but about my friend Sherlock. Imagine trying to memorize the entire New Testament!

After lunch, Sherlock, Lisa and I went down to the communications room on the first platform deck to see if the *Odyssey* was finding anything. Sherlock had learned that the underwater telephone transmissions from the minisub were received in that room and we thought we’d listen in.

Jed Perkins, the ship’s communications officer, had his back to the door when we walked in. He’s a great, big bear of a man with a short, black beard. A voice crackled from the speaker in front of Mr. Perkins. “We’re at 2480 feet,” the voice announced excitedly, “in a narrow, rugged canyon. The wall in front of us is at a forty-five degree slope or so, and we’ve picked up a track in the mud that looks as if it was made by a good-sized, cylindrical object! Something heavy slid down this slope! Visibility is lousy, but we’re going to try to follow the track down. We may be onto something!”

Perkins keyed the switch on his mike. “Could it have been made by the thermometer?” he asked.

“That’s a distinct possibility,” the voice replied.

“Maybe we’ve hit pay dirt!”

Sherlock’s eyes shone with excitement.

“‘Thermometer’ is the code-name for the missing bomb!” he whispered. “This could be it!”

Chapter 8 – The Find

We waited breathlessly, listening as the sub’s pilot continued to fill Perkins in on their progress. The communications officer was so engrossed in what was happening that he didn’t even notice the three of us standing in the doorway. “We’re following the track down the canyon wall,” the voice on the speakerphone reported. “Major, shine the searchlight more to starboard, please. More to starboard, sir. No, the other way... Too late, I lost it!”

There were several moments of silence, then another transmission. “Perkins, we lost sight of the track,” the voice reported. “Visibility is so poor down here, less than three or four yards. I’m trying to keep the sub just close enough to see the canyon wall without touching the wall or stirring up sediment. I’m gonna back off and bring the sub around again...see if I can pick up the track again...”

The speaker was silent again except for a faint hum, which I guessed was the sound of the *Odyssey*'s electric motors. Perkins sat hunched over the desk. Lisa, Sherlock and I stood quietly in the doorway, waiting expectantly. Several minutes passed.

"Got it!" the voice announced suddenly. "Gonna try to follow the track down...

Carefully... Major, swing the lights more this way...perfect! Still with it...the track is still there...going lower...lost it again!"

I sighed. The suspense was killing me!

"There it is again," the voice announced triumphantly. "We're dropping lower...still have the track in sight...oh, brother!" The voice on the speakerphone echoed disgust and disappointment at the same time.

What is it? my mind screamed. I held my breath.

Perkins keyed the mike again. "What is it?"

"Just a stupid 55-gallon drum," the voice replied. "The track was made by an oil drum."

"Oh, great!" I said aloud.

Perkins spun around. "What are you kids doing here?" He looked upset.

"We're just listening," Sherlock replied. "We wanted to know if the *Odyssey* was finding anything."

"You're outta here," the communications officer ordered. "The *Odyssey* is on a special assignment, and no one is allowed in the communications room. Beat it, kids."

"We're gone," Sherlock told him. He gave the man the thumbs up signal. "Good luck finding the nuclear bomb, uh, thermometer." He grinned and turned away.

"Why did you say that about the bomb?" I asked as we strolled up to the main deck.

Sherlock shrugged. "I shouldn't have said it," he admitted, "but I was just a little aggravated that he was so short with us."

The chess tournament resumed after supper. Nearly everyone aboard the *Endeavor II* was present in the dining saloon and the lounge, either to participate or to watch. Lisa wanted to go to the dining saloon and watch her dad's game,

but I headed for the lounge to watch Sherlock. I thought that perhaps my presence might encourage him somewhat.

He was seated across from Chief Mate Webster. The tall seaman gave Sherlock a condescending look and said, "I'll try not to be too hard on you, Son." Sherlock merely smiled.

Ten minutes later, after just a few moves, Sherlock had the man's king in check. "I don't believe this," the tall officer muttered. "This must be my off night."

Webster sat in silence for fifteen minutes, studying the chessboard. He glanced nervously at Sherlock from time to time, but Sherlock just sat with his arms folded across his chest. He looked as if he were made of stone. I don't think he was even breathing.

Finally, Webster sighed. "There's nothing I can do, kid," he said in defeat. "Checkmate." He shook his head. "I can't believe I lost to a kid."

Sherlock grinned. "I'll mark the win on the roster." He stood to his feet and held out his hand. "Good game, sir."

The Chief Mate bared his teeth and growled at Sherlock, who stepped back slightly in surprise at the strange

reaction. The man grinned suddenly and extended his hand. "Good game, Sherlock. But I still can't believe it."

"What happened?" I asked, as Sherlock uncapped a felt-tipped marker and recorded his win on the roster. "How did you win so quickly?"

Sherlock grinned. "The *Endeavor II* has quite an extensive library on CD-ROMs," he replied. "I found a CD-ROM on chess strategies and memorized the basics."

I laughed. "I don't think these people know what they're up against." He laughed and held a finger to his lips.

We floated from table to table, watching the other players engaged in battle. When we slipped into the dining saloon, Lisa hurried over to us. "Your game's over already, huh?" she said to Sherlock. "I'm sorry, Sherlock."

"So is Webster," the young detective replied.

Lisa frowned, not catching Sherlock's meaning.

"Sherlock won!" I whispered.

Lisa's mouth fell open. "You're kidding."

I laughed. "Webster didn't know what hit him."

Lisa smiled. “I think Daddy’s winning,” she told us. “I have to get back to his game.” She hurried back to the table where her father sat across from one of the engineering crew.

“It’s stuffy in here,” I told Sherlock. “I’m going out on deck.”

“I’ll go, too,” he offered. “I’ve had enough of chess for one night.”

Moments later we found ourselves up on the aft end of the 02 deck. The moon was behind the clouds, and the night was dark. Sherlock suddenly grabbed my arm. “Look!” he whispered urgently.

He was leaning over the railing, looking down toward the afterdeck below us. I leaned over, too. “I don’t see anything,” I whispered.

“Somebody’s in the *Odyssey*’s hangar,” he replied. “I just saw a flash of light!”

I leaned farther over the railing. The hangar door was closed, and the windows in the door were all dark. The lights were off. But just then, a faint beam of light flashed across the windows in the door. Someone was in the darkness of the hangar with a flashlight!

“Let’s check it out,” Sherlock whispered. My heart was in my throat as I followed him down two flights of stairs to the main deck. We dashed to the afterdeck of the vessel and crouched beside the hangar door. I held my breath as we slowly rose up enough to peer in the windows.

The hangar was dark except for a faint glow at the front of the minisub. Someone was messing with the *Odyssey*, and I knew it must be the saboteur, or he would have turned the hangar lights on! My heart was pounding so hard that my chest hurt and it felt as if a steel band was constricting around my lungs. I could hardly breathe.

“I can’t see who it is,” Sherlock whispered. He tried the door, but it was locked. “Hide behind the A-frame crane so you can see him if he comes out. I’ll run up and get Captain Stevens.” With those words he was gone, sprinting quietly away into the darkness.

I hurried to a hiding place in the darkness beneath the crane. A cold fear swept over me. What if the saboteur came out and saw me?

The moon came out from behind the clouds just then, brightening the afterdeck with its silvery beams. I ducked

lower in my hiding place. The moonlight made the whole situation less scary, and it would help me to see the mysterious intruder, if he came out of the *Odyssey's* hangar. But it would also make me that much easier to spot.

I pushed the light button on my watch. Where was Sherlock? It seemed as if he had been gone forever. How long could it take just to dash up one deck and reach the dining saloon? The moon ducked behind the clouds again, plunging the afterdeck into a terrifying darkness.

The door to the hangar opened just then. I could barely see the door, but I did hear it slide open with a slight scraping sound. I held my breath. A dark shadow appeared in the doorway. The furtive figure noiselessly slid the door closed, and the latch snapped into place with a faint metallic click.

The saboteur turned the corner and slipped silently along the starboard side of the ship. I rose from my hiding place, not sure what to do. I wasn't about to follow this person, and yet I hadn't even seen who it was. All I needed was one glimpse of his face to make a positive identification. I decided to try to follow at a safe distance.

I hurried to the aft side of the hangar and knelt on the deck as I peered around the corner. The deck was empty.

My heart was in my throat as I hurried forward in the darkness, running my right hand along the ship's rail to keep a sense of direction. A passageway at right angles to the rail led to the Wet Lab, just forward of the hangar, and I paused when I reached it. Had the saboteur turned in there, or continued forward along the rail? I peered ahead in the darkness, but could see nothing. "Lord, what should I do?" I prayed silently.

I heard a faint click as the door in the passageway closed, and I had my answer. Waiting just a few seconds to give the saboteur time to move away from the door, I crept forward. My heart was pounding as if it wanted out. I opened the door as slowly and quietly as possible, stuck my head through, and peered down the passageway. I could see absolutely nothing.

Why was everything so dark—on the deck, and now in the passageway? Had the saboteur turned off the lights? Silently, I slipped into the main passageway.

I crept forward past the divers' lockers, wishing that I could see. A door closed less than ten yards from me, and I

hurried forward. I waited a few seconds, then opened the door as quietly as possible. The sound of running footsteps told me that my prey was on the run, and, in fact, was already more than forty yards in front of me. Once he reached the scientific storeroom, he could go up to another deck, turn right and exit to the foredeck on the starboard side, or turn left and go out on the port side. And if he got there too much ahead of me, I would not be able to hear which way he had gone. I would have to guess, with only one chance in three of being right. I would lose him!

My breath was coming in noisy gasps as I reached the end of the passageway. I was right beside the scientific storeroom. All right, which way did he go?

A tiny click to my left gave me the answer. He had gone out the port side! I hurried forward. The door opened noiselessly, but as I closed it, it slipped from my hand and banged shut. My heart stopped. What if the saboteur had heard?

Footsteps sounded across the foredeck to my right, so I hurried toward the sound. I was back out on the open deck, but

the night was still as dark as a bottle of india ink. I gripped the port rail as I hurried forward.

I heard a tiny noise behind me and started to whirl around. Too late! Strong hands gripped my arm and the back of my jacket, thrusting me toward the rail. Before I even had time to cry out, I was sailing over the rail and falling into the darkness of the cold Atlantic. My assailant had thrown me overboard! As I fell into the frigid waters, I knew that this was no dream—this nightmare was for real!

Chapter 9 – The Dive

The cold of the North Atlantic was intense. The attack had been so sudden that I had not even had time to draw a breath. My lungs screamed for air as I clawed for the surface. My shoes and jacket felt like they were made of lead and were fighting against me as I struggled to reach the surface and grab a breath of air. Arms and legs flailing, I desperately reached upward for life. The water was so very cold, and so very, very dark.

My head suddenly broke the surface, and I gratefully inhaled. The moon seemed to leap from behind the clouds, bathing the ocean in silver-white light. My heart sank. Already I was more than forty yards from the ship! The current must be powerful. I took another breath to let loose with a scream for help, but a wave swept over me, burying my head in a frothing mass of water.

I came up again, choking and coughing. My helpless hands flailed the air, seeking for something solid to grasp, and finding nothing. I spit out a mouthful of salty seawater, coughed a couple of times, and finally got a good lungful of air. But the angry sea plunged my head under again before I could even call for help. After an eternity under the water I came up again, choking and gasping. I was drowning, and I knew it.

I saw the next breaker coming and was able to keep my head above it this time. “Lord, help me!” I prayed. I snatched off my shoes and let them drop.

There was nothing but empty water in front of me now. The *Endeavor II* had vanished; I was alone in a huge, dark expanse of empty water. Panic overwhelmed me. “Lord Jesus, help me!” I cried fervently. “I’ll never see Mom and Dad again!”

The currents spun me about, and I suddenly caught sight of the lights of the ship. I had been facing away from it. But the sight was not reassuring—I was now more than a hundred yards from it. I took a deep breath and screamed, “Help! Help me!” I grabbed another breath. “Help me! I’ve

fallen overboard!” The lights seemed to grow smaller and smaller and I realized that I was closer to death than I’ve ever been in my entire life.

I concentrated on paddling into each wave, desperately struggling to keep my head above water. I’ve never been a strong swimmer. Sherlock says that females typically are better swimmers than males for the simple reason that they have a higher percentage of body fat, and therefore, more buoyancy. But I’m so skinny that there’s not an extra ounce of body fat anywhere.

Having caught my breath, I threw every ounce of energy I possessed into swimming back to the ship. I tried. I really did. With all my heart and soul I tried. But the currents were against me, and steadily swept me farther and farther from the ship. Discouragement swept over me as I realized that I could never hope to make it back against the force of the powerful current. I went back to simply fighting to keep my head above water.

My struggles had stirred my blood and warmed me somewhat so that the water no longer felt so bone-chilling cold. But I was steadily growing weaker, and I knew that I couldn’t

last much longer. “Lord Jesus, help me,” I sobbed. “I don’t want to die this way, out here alone in the dark. Please, Lord Jesus, help me!”

The next wave caught me unawares, flipping me over on my back and plunging me beneath the surface again. My mouth and nose filled with stinging seawater. Sputtering and choking, I struggled to the surface for a breath of air. “Help me, Lord!” I cried aloud. “I can’t make it!” I was going to die, and there was no way out. The only person who even knew where I was had deliberately thrown me overboard.

I considered simply swallowing water to make the end come more quickly. But I found that I just couldn’t give up. Life was too precious; I wanted to live to serve the Lord. “Lord,” I sobbed, “I’m in Your hands. If You want me to live, You’ll have to make a way.” I don’t know if I even said the words aloud.

But He heard me. At that moment, something hard and cold bumped against the side of my face. I seized it in both hands. To my amazement, I was clutching a picnic jug! A hard plastic, two-gallon picnic jug with a sturdy handle. And the lid was on tight! The jug was full—full of air. And two

gallons of air is enough to keep anyone afloat. Wrapping both arms around the jug, I pulled it up under my chin and hugged it tight.

For the next several minutes I simply clung to the jug and rested. I no longer had to struggle; the jug would keep me afloat. Even the waves weren't going to put my head under now! "Thank You, Lord Jesus," I wept. "Thank You, thank You." No one will ever convince me that God doesn't answer prayer. What were the odds of that picnic jug finding me in that huge ocean simply by chance?

The cold seemed to come back with a vengeance. The sea simply wasn't going to give up that easily; if it couldn't kill me one way, it would find another. I decided to keep my legs moving in a slow kick just to keep my circulation going.

I turned in a slow circle, scanning the water in all directions. The *Endeavor II* was nowhere in sight; I was on my own. Lost. Alone at night in the Atlantic Ocean, and not a soul on earth knew where to find me. It was a terrifying thought.

What if there are sharks? The idea was more than I could bear; terror overwhelmed me. My heart started racing

and my breath came in short, shallow gasps. My arms felt like rubber, and suddenly, I no longer had the strength to hang on to the picnic jug. *Sharks!* My chest constricted with fear, and I found that I couldn't even breathe. My head slipped into the water and I realized that I had lost my hold on the life-saving jug without even realizing it. I grabbed the jug and frantically pulled myself up as high as I could out of the water. "Lord, help me," I prayed. "Take the idea of sharks from my mind. I need You, Lord!"

I suddenly thought of Mom. I could see her friendly smile, her curly hair, her gentle hands. "Mom," I sobbed aloud, "I miss you." I thought of Dad. Would I ever see his cheerful face again?

I guess I drifted for another several minutes. In spite of my kicking, the cold slowly overtook me. It seeped into my body, numbing my senses, loosening my grip on the picnic jug. My mind seemed to be in a fog. I was about to lose my battle against the sea, but I no longer cared.

The water around me seemed to grow dark abruptly, and I was still alert enough to wonder why. Less than ten feet in front of me, the moonlight splashed across the tops of the

waves, sparkling and glistening. But the water around me had grown as dark as ink. I gave an extra kick and spun the jug around, peering into the darkness behind me.

It was as though the sky had vanished. The moon and the stars had disappeared as if they had been wiped from the sky. There were no clouds, just a dark, empty void above and beyond me. It was eerie. I spun around and faced forward again, and all looked normal. I could see the stars, and even though I could not see the moon, I could see its light reflected of the tops of the waves.

Fighting a rising panic, I looked behind me again. That same black, empty void still loomed over me. *What is happening?* I thought in desperation. *Is this what it's like to die?* It was as though a black hole loomed beyond, ready to swallow me up.

Think, Penny, think, I told myself. *There has to be a logical explanation for this. There are no black holes at sea!*

The answer hit me. I had floated up against something that was blocking my view of the sky. Something big. Like a ship!

“Help!” I shouted. “Help me!” I kicked backward with renewed vigor and banged my shoulder against cold, hard steel. It definitely was a ship. Letting go of the picnic jug with one hand, I reached up and rapped my knuckles against the hull just to be sure.

“Help!” I shouted again. “Man overboard! Girl overboard! Help me!”

It suddenly occurred to me that the occupants of the ship would not even be able to see me if they did hear my frantic cries; I was too close. I was actually under the edge of the hull. Clutching my precious picnic jug, I kicked away from the side until I could see the ship's lights above me.

“Help!” I called again. “I'm in the water! Man overboard! Help!”

A searchlight snapped on and began to sweep across the water. I called again. “Help!” The brilliant beam swept across me and continued on. They hadn't even seen me. I raised one hand and waved. “Over here!”

The light swept past me a second time, hesitated, and then swept back and stopped right on me. It was blinding, but I figured they could see me, and that's what mattered. “Hold

on!” a welcome voice called. “We’ll have you aboard in no time!”

Seconds later, I heard a heavy splash as something big hit the water less than fifteen feet from me. A grinning sailor bobbed to the surface right beside me with a life jacket in his hands. “Hold on,” he told me. “I’ll have this on you in just a second.”

He began to fasten the life jacket around me. “What’s your name?” he asked.

To my amazement, I couldn’t even remember. I started to cry. He squeezed my shoulder. “You’re going to be OK,” he told me. “We’ll have you safely on the ship in about two minutes. It’s going to be all right.”

A canvas seat came swinging down toward us on the end of a line. The sailor helped me into it and fastened a belt around me. “The elevator’s going up,” he said. He raised his hand in a thumbs-up signal to somebody above us. Thirty seconds later, I was safely aboard the ship.

Lisa hugged me as I stepped from the helicopter, safely aboard the *Endeavor II* once again. “What happened?” she asked. “We were so worried!”

I laughed weakly. “It’s a long story.”

She cast a puzzled glance at the Thermos jug in my hand. “What’s that for?”

“That’s part of the long story,” I told her. “This jug saved my life! I saved it as a souvenir of my brush with death. It will always be a reminder to me of the goodness of God, and the fact that He answers prayer!”

She giggled. “You look funny in that over-sized pea jacket.” She hugged me again. “Oh, Penny, do you realize what could have happened?”

I nodded. “Believe me, I had plenty of time to think about things like that.”

Sherlock was waiting on the 02 deck at the base of the stairs. I rushed down to him. “What happened in the hangar?” I asked.

He held up his hands. “Wait, Penny. First things first. Are you OK?”

I nodded. “I think so,” I replied. “I just feel very, very tired.”

He looked at me for a long moment without saying anything. He swallowed hard. “Penny, please be more careful next time. You could have been killed!”

I shrugged and nodded, feeling like a kindergartner being scolded for playing in the street. “I know,” I said meekly. “I’ll be careful.”

He grinned at me and squeezed my arm. “I’m glad you’re OK, Penny.”

“Did the saboteur do any damage to the *Odyssey*?”

Sherlock grimaced. “He tried. We discovered a timed explosive device fastened to the hull of the sub, with less than six minutes left on the timer. Captain Stevens got Lieutenant Owens to disarm it in time so it didn’t do any damage.”

“Lieutenant Owens?”

“Yes. He’s an ordnance specialist, remember?”

Mr. Diamond stepped forward and hugged me. “Thank God you’re alive, Penny.”

What happened?” He looked me over and said, “Let’s get you down to the stateroom and into some dry clothes, and then you can tell us your story.”

As it turned out, the ship that I had drifted to was the *U.S.S. Bumble Bee*, one of the two Navy destroyers that were assisting in the search for the missing bomb. I had floated more than three miles from the *Endeavor II*! But if I hadn’t run into the *Bumble Bee*, I would have floated out to sea, and there’s no way I would have survived the night in that cold water. God was merciful to me.

The next morning, Captain Stevens called an emergency meeting of all the ship’s personnel. Everyone on board the *Endeavor II* was present, from the lowest crewmember to the Chief Scientist. The only exception was the Third Mate, who was on deck duty. The captain looked about the dining saloon, and then cleared his throat. “Most of you are well aware of the fact that we are engaged in a top-secret assignment involving the U.S. military. Up till now, the nature of our mission has been classified, and we’ve been compelled to keep the details from most of you. As you know, there have been two sabotage attempts to disable or destroy the

Odyssey. The latest attempt failed, thanks to the alertness of two young people and the expertise of Lieutenant Owens.”

I glanced at Owens and saw him give a slight nod acknowledging Captain Stevens’s compliment.

“But the worst news is that an attack was made against a young lady on this vessel. In fact, she was thrown overboard, which is, of course, attempted murder. Thank God, she survived her ordeal.” Captain Stevens paused.

“There is a possibility that some of you could be facing personal danger, and that is why I have called this meeting. The saboteur or saboteurs, who were also last night’s assailants, apparently are on this ship. There is nothing to indicate otherwise. So far, we have no clues as to the identity of this person or persons. I’m asking each of you to be alert, not only for your own personal safety, but also for the well being of the ship and our mission. The saboteur is undoubtedly in this very room right now.”

I heard several gasps of surprise as the captain’s words sank in. People looked fearfully about the room as if they were in danger at that very moment.

“Colonel Andersen has granted me permission to acquaint you with the details of our mission in order that you might be aware of the seriousness of the situation we’re facing. Less than a month ago, the United States Air Force lost two planes in a refueling accident. I won’t go into the details, but when the planes went down, a critical component was lost at sea. The *Odyssey* is searching for that item. We have reason to believe that an antagonistic country with a history of terrorism is aware of the situation and is attempting to thwart our efforts at recovering the item. Possibly, the saboteur is an agent of that country. That’s all I can say at the moment, but I wanted you to know what we’re up against.”

Captain Stevens then fielded several questions from the group, answering some specifically and giving vague, general replies to others that dealt with the military aspects of our situation. He certainly wasn’t giving out any unnecessary information.

The *Odyssey* dived again that morning, so after lunch, Sherlock, Lisa and I went down to the communications room to

see if the minibus was finding anything. We approached the door cautiously, intending just to ask a few questions. To our surprise, Perkins, the burly communications officer, gave us a warm welcome. “Come right in!” he invited. “Sorry to be so...so abrupt yesterday. The mission was top secret, you know, and I had to keep a lid on things. But when I told Captain Stevens about your visit, he informed me that we didn’t have to keep any secrets from you.”

Sherlock grinned. “Thanks.” He glanced at the speaker on the desk. “Any word from the *Odyssey*?”

Perkins shook his head. “They’re searching some pretty rugged terrain. Rogers says it’s like going into the Grand Canyon at night, covering one eye, peering through a paper towel tube with the other, and hunting for a tennis ball. The *Odyssey* hasn’t found anything yet.”

We stayed for several minutes, talking with Perkins and allowing him to show us the radio and INMARSAT satellite communications equipment. Sherlock was fascinated and asked a million questions, but Lisa and I were a bit bored. Finally, after what seemed like hours, we got ready to leave.

“Thanks for your time,” Sherlock told the friendly communications officer.

“Any time,” Perkins told us. “Thanks for dropping by.”

I followed Sherlock and Lisa from the communications room. Just then the speakerphone crackled to life. “Perkins, you there?” I dashed back into the room to find out what was going on.

Perkins grabbed the mike. “Right here. Whatcha got?”

“Don’t know yet,” the speakerphone replied. The voice was that of Wellington, and we could tell that he was trying to keep the excitement out of his voice. “We’re at 2693 feet. Holloway spotted a light-colored object a moment ago, but we lost it, and we’re trying to navigate our way back to it. It looked cylindrical, and we think it could be the thermometer. Stand by—I’m bringing the *Odyssey* around for another pass.”

I held my breath. There were several moments of complete silence, then another transmission from the sub. “Yes! This could be it, Perkins! This thing is sitting precariously on a 70-degree clay slope that looks as slick as glass. We could lose it at any time, but it looks like we hit pay dirt!” We heard the whirr of the minibus’s motors.

“It’s...it’s...got lettering stenciled on the side and...Perkins, this may be it!”

Perkins keyed his mike. “Can you make a positive ID?”

“No, visibility is not the best and when we move in too close we stir up a lot of sediment, but that has to be it.”

“Give me your coordinates,” Perkins requested, referring to the sub’s position.

The speakerphone responded with a string of numbers that I knew were the exact longitude and latitude of the *Odyssey*. Perkins punched the numbers into the computer terminal in front of him. “This will log the position into the dynamic positioning system,” he told me. “The *Endeavor II* will stay right on top of it.”

“We’re getting photos,” Wellington reported. “We’ll surface in a bit for a marker buoy and line. Perkins, this is it! We found it, at last!”

“Congratulations,” Perkins responded. “Good work. I’ll pass the word to Captain Stevens.”

Lisa stuck her head in the door. “Penny, are you coming?” she called. “Sherlock and I went up to the main deck and discovered that you weren’t with us!”

“Lisa, they found it!” I exclaimed. “We think they found the uh, thermometer! You guys missed it!”

Lisa and Sherlock hurried into the communications room. “The *Odyssey* found the bomb?” Sherlock repeated incredulously. “When?”

“Just now! Just as we went out the door, the *Odyssey* called back to say that they had spotted it. I ran back in, and I thought you were right behind me.”

Sherlock looked crestfallen. “I can’t believe we missed that.”

I laughed. “Now you know how Rogers will feel when he finds out about it. At least they found it!”

“Preparing to surface,” Wellington reported just then. “We’ll start up in just a minute or two.”

“Affirmative,” Perkins replied. “Nice going, guys.”

Sherlock turned to Perkins. “Nice work! Tell Wellington congratulations for me.” We slipped from the communications room, chattering excitedly about what had just

happened down in the depths below the ship. I could tell that Sherlock was glad they had located the missing bomb, but still disappointed that he hadn't been present in the communications room to hear the transmission from the mini-sub when they actually made the find.

The *Odyssey* surfaced half an hour later near the stern of the *Endeavor II*. As Sherlock, Lisa and I watched from the 02 deck, a diver swam out to the minisub and placed a nylon line in the sub's remote control claw. One end of the line was fastened securely to a metal spike, which the *Odyssey* would attempt to drive into the ocean floor near the new discovery; the other was secured to a marker buoy. If for some reason the minisub couldn't locate the object by navigating, the buoy line would lead her right to the spot. Finally, it seemed that we were making some progress in our mission to recover the missing bomb.

The chess tournament resumed after dinner that night. Excitement was high; the mood was festive. Even as they moved bishops and pawns and captured each other's game

pieces, the players discussed the *Odyssey's* mission. The crewmembers who were not in the know made all sorts of wild speculations as to the nature of the operation; but I noticed that the officers and military men—those who did know—weren't saying anything.

To the surprise of many of the spectators and players alike, Sherlock won his next game, playing against Major Ward Smith, who was favored as a likely contender for the championship. Mr. Diamond also won his game against one of the scientists, and so did Lieutenant Owens and Captain Stevens. A number of players suffered their second defeat of the tournament and were eliminated from the competition.

At breakfast the next morning, Captain Stevens led our table in prayer. The six military officers were not present. "I have some bad news," he announced, after concluding his prayer of thanks. "Our mission to recover the missing bomb has just suffered a major setback. The crew discovered less than an hour ago that someone has erased the location coordinates from the ship's dynamic positioning system and

entered a new position. The *Endeavor II* is more than a mile from the position she held last night!”

Sherlock spoke up. “It’s fortunate that the *Odyssey* was able to place a marker buoy,” he said.

The captain shook his head. “We sent two divers in one of the motorized workboats,” he replied. “They just returned. The marker buoy is gone! The same person or persons who erased the data from the positioning system have apparently also cut the line on the marker buoy! We’ll have to start our search all over again!”

Chapter 10 – Deep Trouble

The *Odyssey* dived again that morning. Ed Rogers had recovered from his illness and was back aboard, eager to play a part in the attempt to locate the missing bomb a second time. We had no proof that the *Odyssey*’s first find was actually the bomb, but Mark Wellington was reasonably certain that it was. Today might have been the day that we actually pulled the bomb up from the ocean floor, had it not been for the interference of the unknown saboteur.

Even Sherlock had no clues as to the identity of the person who was so determined to stop our mission. There had been no fingerprints at the scenes of the crimes, no clues of any kind, absolutely nothing to point to the person or persons responsible. Captain Stevens had told Sherlock that whoever erased the data from the ship’s dynamic positioning system could only have done so from the communications room or the

bridge, and both were kept locked at all times that they were unoccupied. Sherlock had examined the locks, but there were no marks of any kind. It looked as if the saboteur had Ving cards to both locks.

Captain Stevens had posted a round-the-clock guard at the Odyssey's hangar. Two Navy Seals from one of the other ships had come aboard and were alternately standing guard day and night in four-hour shifts.

Shortly before time for lunch, Sherlock and I went down to the communications room to check with Perkins on the sub's progress. "Nothing yet," the big communications officer replied despondently when we asked. "Rogers and Wellington are pretty discouraged about this whole thing. They were expecting to pull up the bomb today, and instead, we're starting the search all over again."

"They'll find it again," Sherlock said in an attempt to cheer Perkins up. "At least this time they know what to look for. They'll recognize the area once they come to it."

Perkins shrugged. "I hope so, Sherlock. But there isn't much time. We got word on the weather band this morning that a tropical storm is forming to the south, and is expected to

reach this region in five or six days. We must find and recover the bomb before then. We have to. And Rogers is afraid that the bomb will slide from its resting place and drop into the chasm below the ridge. If it does, we may never find it."

The sub surfaced that evening without accomplishment. The missing bomb was still missing. The crew was discouraged and the Air Force officers were frustrated. Everyone aboard the *Endeavor II* was keenly aware of the fact that the saboteur was responsible. Worst of all was the knowledge that he was probably aboard with us, undetected, able to strike again without warning. Many of the crew were starting to refer to the unknown saboteur as "The Phantom."

The chess tournament that night seemed to help with the low morale. During the two hours or so that the competition was in progress, the players and spectators alike relaxed and momentarily forgot about the mission's failure. Mr. Diamond won another game, and, just as I expected, Sherlock was well on his way to another victory of his own.

I didn't stay for the entire time, though, because I started feeling dizzy again. When it became obvious that Sherlock was going to win his game, I turned to Lisa. "I think I'll go to the stateroom and lie down," I told her. "I'm not feeling too well." Intent on watching the chess game, Lisa just nodded. I slipped out into the night.

Maybe Lisa's right, I told myself as I headed down the stairs. Maybe that bump on the head did give me a slight concussion or something. But if I tell anyone about it, they'll probably make me go to the ship's infirmary and then I'll miss all the fun. I decided not to tell anyone unless it got really bad.

I reached the bottom of the stairs just then and gave a hard shove on the door, which flew open and then stopped abruptly as it whacked into somebody. I heard a grunt of pain. Timidly, I peered around the edge of the door. Colonel Andersen was standing there, holding his right wrist as if it were injured. Papers were scattered all across the deck, and I realized that I had knocked them out of his hand.

"I'm sorry, sir," I stammered, dropping to the deck to gather the scattered documents. "I didn't see you."

The colonel didn't answer; he just stood there glaring at me as I crawled around the deck gathering his papers. I sheepishly handed him the crumpled papers, apologizing again, but he never said a word. He just took them from me, gave me a hard look, and disappeared through the door, slamming it behind him. I leaned against the bulkhead for a moment, fighting to maintain my balance as another wave of dizziness swept over me.

I slowly became aware of the fact that I was standing on a sheet of paper. Apparently, I had missed one of Colonel Andersen's documents. I knelt and picked it up, then studied it in the dim light. The document was a fax, but the message on the paper didn't make any sense at all: it was just a jumble of letters, numbers, and mathematical symbols that didn't mean anything. I opened the door to catch Colonel Andersen, but the stairwell was empty. I decided to go directly to our stateroom and lie down. I would give the paper back later.

When I reached the stateroom, I spent a few minutes studying the assortment of strange symbols in the fax message. As far as I could tell, they made no sense whatever. *This had to be some kind of a code, I told myself. Maybe Sherlock can*

figure it out. I'll have to show it to him before I give it back to the colonel.

Fifteen or twenty minutes later, Sherlock, Lisa and Mr. Diamond came bursting into the stateroom, chattering excitedly about the chess tournament and waking me from a nap. I rolled over and sat up. "How did it go?" I asked.

"I won my games and Sherlock won his," Mr. Diamond told me. "I can't wait for the chance to play against Sherlock."

"You know who will win that one, don't you?"

Sherlock teased. "But I'll go easy on you, sir."

Mr. Diamond grimaced. "Thanks, Sherlock, I'd appreciate that." He grinned. "You play me, Son, and you'll do well to last five minutes." Lisa and I laughed. Mr. Diamond opened the door to the little bathroom and slipped through to the stateroom that he shared with Sherlock.

I suddenly remembered the fax that Colonel Andersen had dropped. "Take a look at this, Sherlock," I urged, thrusting the paper at him. "Isn't this the craziest thing you ever saw?"

Sherlock studied the fax for a few seconds. "Where did you get this, Penny?"

"Colonel Andersen dropped it," I replied. "But look at it, Sherlock! It doesn't make any sense at all!"

"It's in code," he told me. "Penny, you know we have to give this back to the colonel."

"I know," I told him, just a little peeved that he would imply that I was planning to keep it. "But look at it. It doesn't make any sense at all!"

"I'm sure it does to somebody who knows the code," he replied.

"Could you figure it out?"

He shrugged. "I'm sure I could, given enough time, but we have to give it back to Colonel Andersen."

"Memorize it," I urged. "Then we can give it back to Colonel Andersen and you can figure out the code."

His eyes dropped to the page in his hand. He studied the message for about sixty seconds and then handed the paper to me. "Got it."

I laughed. "You're incredible!"

He just smiled and headed for his stateroom. "Good night, Penny. Good night, Lisa."

The next morning as the four of us were heading up to the dining saloon for breakfast, I fell into step beside Sherlock. “Did you figure out the code?” I whispered.

He grinned sheepishly. “I stayed awake half the night.”

“Were you able to figure it out?”

He nodded, and a really serious look crossed his face.

“The fax was from some bigwig Chief of Staff at the Pentagon,” he told me.

“What did it say?”

“It asked Colonel Andersen for a report of the progress of the mission and stressed the need for secrecy and top-security measures. But what puzzled me was this: the message stated that if the mission ended in failure, a certain trade agreement with Beijing would be jeopardized.”

“Beijing?” I echoed. “As in Beijing, China?”

Sherlock nodded.

“So what does China have to do with all this?”

He shook his head. “I don’t know...yet. But we’re going to find out.”

Sherlock and I were so intent on our discussion that neither of us realized that we had stopped walking. “Come on you guys!” Lisa hollered. “We’re gonna miss breakfast!” I looked up. Lisa and Mr. Diamond were standing at the top of the stairs, ready to walk out on the 01 deck. Sherlock and I hurried to catch up.

Our time aboard the *Endeavor II* flew rapidly by. Late in the afternoon of the third day of the new search, Lisa and I were heading to our stateroom and as we passed the communications room, Perkins stuck his head out and waved at us. “Good news!” he greeted us. “The *Odyssey* just found the bomb again! They planted two sonar transponders in the bank beside the find, and they’re surfacing in just a few minutes to get a marker line and take it down.”

“What are ‘sonar transponders’?” Lisa asked.

“They transmit sonar signals, which will enable the *Odyssey* to go right to the bomb. We’re cooking, now! Even if The Phantom cuts the line to the marker buoy, there’s no way he can remove the sonar transponders! We have the location

coordinates back in the positioning system, and I took it a step further than that.” He extended his arm toward us, and Lisa and I both saw that he had written the bomb’s position on his forearm in red ink! He grinned at us. “I’d like to see The Phantom try to erase that!” We laughed.

“The Odyssey has to come up to recharge her batteries,” Perkins told us, “but she dives first thing tomorrow morning. And when she comes back up tomorrow, so does the bomb!”

It was a light-hearted group that gathered in the dining saloon for the chess tournament after supper. Each division was down to four players now, and ironically, fifteen of the sixteen had one loss apiece. The only undefeated player was Lieutenant Owens. Unless the lieutenant succumbed tonight, the eight who lost tonight were out for good; tomorrow night’s competition would determine the winners in each division. After that, two more nights of chess would determine the tournament champion.

The tournament that night went just as I expected. Sherlock won another game, as did Mr. Diamond, Lieutenant Owens and Captain Stevens. I had predicted all four wins. I didn’t notice who won the other games; to me it didn’t matter.

Lisa and I congratulated Mr. Diamond and Sherlock on their wins as we walked back to our staterooms. “Thanks,” Sherlock replied glumly. “I just wish that you could congratulate me on something else as well.”

“What’s that?” I asked.

“Solving the mystery of the saboteur’s identity,” he answered. “He’s struck several times now, and we still have no clue to his identity. He slips through locked doors without leaving any indication that he’s been there. No wonder they’re starting to call him ‘The Phantom.’ Remember when Rogers got sick? His symptoms indicated food poisoning, and I’m beginning to suspect that was the work of The Phantom, too.”

Something clicked in my brain when he said that. It was as though my mind was trying to make some kind of connection between Sherlock’s statement and something else that I knew, but I just couldn’t recall what it was. I tried and

tried, but it was like trying to place a long distance call on Mother's Day. The signal didn't get through.

"It's as though The Phantom has his own set of Ving cards," Mr. Diamond commented. "He has access to any part of this ship that he wants."

"Is there someplace where they keep all the Ving cards?" I asked. "Could the saboteur possibly have gotten hold of some spare cards?"

"I asked Captain Stevens about that," Sherlock told me, "but he insisted that the only ones with Ving cards to the hangar are Webster, Colonel Andersen, and himself. He had the lock on the hangar changed the first day he started securing it."

We reached our staterooms at that point. "I've been praying for wisdom," the young detective said, "but I'm still in the dark."

"Did you figure out what this whole thing has to do with China?" I asked.

He shook his head. "Not yet."

"How are you doing on your memorizing?" I asked as Mr. Diamond inserted his Ving card and opened the door.

"I finished II Timothy," Sherlock told me, "and I've done the first chapter of Titus."

"Goodnight, girls," Mr. Diamond said. "See you in the morning."

"Tomorrow's the day that we bring up the bomb," I replied, "unless The Phantom strikes again."

"Please, don't even say that," Sherlock begged. He and Mr. Diamond disappeared into their stateroom.

The afterdeck was crowded with spectators as the technicians prepared to launch the *Odyssey* the next morning. It seemed that everyone aboard the *Endeavor II* not assigned to a duty station was present to wish the pilots well. Crewmembers, ship's officers, scientists and military officers alike swarmed over the minisub as it sat under the A-frame crane, eager for its long-awaited trip to the ocean floor to snatch up the missing bomb. The technicians did their final checks; the pilots fastened the hatch closed; and the crane hummed as it hoisted the *Odyssey* from its cradle.

The minisub clutched a special steel harness in its remote control claw. The purpose of the dive was to secure the harness around the bomb, then return to the surface for a special lift cable to attach to the harness. If all went well, we could expect to have the missing bomb on deck by mid-afternoon.

The two divers were already in the water when the minisub touched down on the Atlantic's choppy surface. The crane whined to a halt as the breakers tossed the little craft gently about. The divers freed the lift cables, and the *Odyssey* slowly sank deeper in the water as the pilots flooded her ballast chambers. It was going to be a perfect launch. I glanced across the crowd and saw smiles of satisfaction and accomplishment. This was the moment we had been waiting for.

"Oh, no!" Sherlock cried aloud, and my gaze leaped back to the half-submerged minisub. A small hatch just forward of the main hatch had somehow flopped open and was now flooding with water. "That leads to a large buoyancy sphere," Sherlock lamented. "If it fills with water, the sub will be too heavy to navigate! She'll sink straight to the bottom!"

Even as he spoke, the *Odyssey's* bow was canting down at a strange angle. We had seen several launches, and she never submerged like this. The water continued to pour into the open hatch and the submersible sank from sight bow first, disappearing faster than I had ever seen her go down.

"She's in trouble," Sherlock whispered. "Serious trouble!"

The gray waters of the Atlantic closed over the *Odyssey's* main hatch with a strange gulping sound as she abruptly disappeared from sight. We had never seen her dive so quickly. It was as though a giant hand had jerked her beneath the surface. The technicians stood on the fantail of the *Endeavor II*, staring in astonishment.

Sherlock grabbed my arm. "Come on!" he whispered, "let's get to the communications room and find out what's happening!" Heart pounding with excitement, I followed him to the first platform deck. Perkins didn't even notice as we entered the communications room.

"I'm clearing the ballast tanks," Ed Rogers, the sub's pilot, reported on the speakerphone, "but we're still dropping like a rock! We've already passed 2,000 feet."

Perkins keyed his microphone. “Drop your dive weight.”

“We tried that,” the pilot responded, “but we’re not sure that the weight actually released. It didn’t slow our descent one bit.”

“Ballast tanks are now clear,” Wellington reported moments later. “I’m dropping the recovery harness.”

“We’re still dropping,” Rogers cut in. “We’re passing 2,700 feet...2,750... 2,800...” As the sub continued to slice downward, he called out the depth of their descent until the sub finally came to rest at a depth of 3,946 feet. “From what I can see, we’re sitting on the very edge of a deep chasm,” he reported. “It looks like the *Odyssey* buried her nose in a mud bank, and we’re tilted forward at about a thirty degree angle. I can’t see how close we are to the edge, but on the starboard side it drops away into absolute darkness. There’s no way to tell, but it looks mighty deep.”

Through the speakerphone we heard the whirr of the minisub’s electric motors increase in pitch until they were almost at a whine. “We’re stuck fast!” Rogers reported breathlessly a moment later. “I can’t even move the sub at full

reverse!” He was trying to keep his words even and calm, but we could all sense the raw edge of fear in his voice.

Perkins’ hand trembled as he placed the mike on the desktop. “They’re in serious trouble,” he told us in a shaky voice. He passed a hand over his face. “And there’s nothing we can do for them.”

Chapter 11 – Ving Cards

Sherlock and I stared at the trembling communications officer. “There’s nothing we can do,” Perkins repeated. “The sub is doomed.”

Captain Stevens entered the door just then with several of the military officers at his heels. One look at Perkins’ face, and the captain immediately knew the worst. “The sub’s in real trouble, isn’t she?” he asked softly.

Perkins nodded slowly without even glancing in the captain’s direction. “She bottomed out at 3,900 feet,” he said wearily. “They’re stuck bow first in the mud, and they don’t have enough buoyancy or power to pull free.”

Captain Stevens shook his head. He grabbed the mike. “Rogers? Wellington? Captain Stevens here. We’re working on a way to get you out of this. Stay cool, boys. We’re with you all the way.”

Wellington’s voice crackled from the speaker. “It’s no use, Captain. It would take you at least three days to get another submersible in here, and another day or two at best to find us. We don’t have that much time.”

I glanced at Sherlock. “How much time do they have?”

“The carbon dioxide given off by the pilots is absorbed by lithium hydroxide,” Sherlock replied, “and additional oxygen is pumped into the cabin to maintain normal pressure. This life support system can keep three men alive in an emergency for 48 hours.”

“Then can it keep two men alive for 72 hours?” I asked.

Sherlock nodded. “Theoretically, yes.”

Colonel Andersen turned to Captain Stevens. “How long would it take to get another submersible on location?”

The captain clenched both fists in frustration. “Wellington’s right, sir. A minimum of three days to get another sub here, and at least another day or two to find the Odyssey. We simply don’t have that much time. There has to be another way.”

Perkins spoke up. “I hate to bring it up, sir, but we have only four more days at most before the tropical storm gets

here. There's no way we can undertake a rescue operation once the seas get rough."

Captain Stevens nodded grimly. "Of course."

Sherlock approached the captain. "What if you could decrease the sub's weight by a thousand pounds? Would that be enough to break her free from the mud?"

Captain Stevens looked puzzled. "How would you do that?"

"Jettison the forward battery," Sherlock replied. "It weighs a thousand pounds, and it's in the bow, right where you need the additional buoyancy."

Stevens took off his captain's hat and ran his fingers through his thick, white hair. "That's a good idea, Son, but there's no way to do that."

"But there is, sir!" Sherlock insisted. "I read it in the sub's manual."

Captain Stevens picked up the mike. "Rogers, is there any way to jettison the forward battery?"

"No sir," the pilot's voice replied. "But that's no good, anyway, sir. That would cost us our side thrusters, lights, and all maneuverability."

The captain glanced at Sherlock and shrugged. "It was a good idea, anyway, Son."

"But it's in the manual!" Sherlock protested. "It's listed under emergency procedures. There's a handle under the instrument panel that jettisons the forward battery, and a switch that ties the two electrical systems together so that the sub doesn't lose any functions."

Captain Stevens thought it over. "Tell Rogers and Wellington that we're working on a possibility, and to stay patient," he told Perkins. He turned to Sherlock. "Let's go to the library and check the manual."

It turned out that Sherlock was right. Just as he had said, the manual did give an emergency procedure for dropping the thousand-pound battery in the sub's bow and switching the sub's two electrical systems together. Captain Stevens himself read the instructions over the speakerphone to the two trapped pilots.

We waited breathlessly as the men carried out the manual's instructions. "We're ready, sir," Wellington reported several minutes later. "The kid was right! That *did* drop the

forward battery! Rogers is ready to try to back us out of this nightmare! Let's hope this works!"

Captain Stevens pushed the mike button. "We're with you! Good luck!"

We heard the whirr of the *Odyssey's* motors. "Come on, girl, you can do it!" Rogers coaxed the sub. The whirr increased to a whine. "Come on...come on..." Rogers' voice was tense, and we all knew what was at stake. "Come on, *Odyssey*, you can do it, girl! Give it your best, Sweetheart!"

Then we heard Wellington's voice. "We moved, sir! Try hard left, then full astern again! Maybe we can rock her free!" Wellington was eager, hopeful. We leaned forward intently.

The whirr of the electric motors changed in pitch as the trapped minisub struggled to break free from her watery grave so far below us. "Come on, come on..." Rogers coaxed. "You can do it...we're moving...Yes! We're breaking free! We're breaking free! We did it!" The last sentence was shouted, a grateful cry of victory.

The communications room was a scene of noisy confusion as we danced around and cheered in relief. The ordeal was over.

I looked at Sherlock. "How did you know?"

He shrugged. "It was in the manual."

Once the *Odyssey* had jettisoned the battery and broken free from the mud bank, she had enough buoyancy to bob to the surface and power over to the *Endeavor II's* stern to be hoisted aboard by the A-frame crane. Rogers and Wellington received a stirring round of applause as they stepped out on deck. Fortunately, the fire several days earlier had not damaged the battery in the bow, so there was a spare waiting in the hangar. If the technicians could repair the hatch lock that gave way, the minisub could dive again tomorrow.

The rescue was the topic of conversation at dinner that evening. The latest and most shocking bit of information was that the hatch failure could be attributed to the Phantom; two of the three bolts on the closure mechanism had been removed.

“But how could that be possible?” Mr. Diamond protested. “There was a Navy Seal on guard all night! No one could have gotten near the *Odyssey*!”

“It was done this morning in broad daylight,” Sherlock told him, “while the *Odyssey* was being prepared for launch!”

“But that’s impossible,” Mr. Diamond argued. “The sub was surrounded by people! The afterdeck was swarming with them!”

“Exactly,” Sherlock replied. “And that’s the problem. The afterdeck was so busy that no one noticed when the saboteur slipped in with a power wrench and removed the two bolts. The person who did it was probably acting like he was helping prepare for the launch.”

“Oh, great!” I groaned. “So we all saw the Phantom at work and didn’t even notice!”

He nodded. “Apparently.”

Captain Stevens came to the table just then, dropping his sunglasses and Ving card on the table beside his plate as he took his seat. He led in prayer, and then Miss Parris served our table. Colonel Andersen had called a special meeting of the

military officers to discuss the sabotage situation, so there were six empty seats at the table.

Sherlock was seated in the end seat closest to Captain Stevens. “Captain, the saboteur has to have a master Ving card like yours,” Sherlock told him. “It’s the only possible explanation for the way he has been able to access the *Odyssey*’s hangar, the communications room, and the bridge.”

Captain Stevens shook his head. “But that’s impossible, Sherlock. Only three master cards were ever made: this one, Webster’s, and the one in my safe.”

“But suppose the saboteur copied your card,” Sherlock suggested. “It would be a very simple matter to make a duplicate in the ship’s machine shop.”

“How could he? This card is *always* in my possession. And Webster keeps a close watch on his.”

“But you always lay your card on the table with your sunglasses,” Sherlock pointed out. “What if the Phantom simply memorized the card and then duplicated it?”

The captain laughed. “I’m glad you’re looking for a solution, Son, but what you just described is not likely. In fact, it’s impossible.”

Sherlock slid the captain's card over beside his own plate, studied it for a few seconds, and then slid it back. "Watch this, Captain," he suggested. He then took a paper napkin and proceeded to draw a pattern of green dots on the napkin. When he finished, he reached for the captain's Ving card and placed it beside the napkin. He had reproduced the pattern perfectly!

Captain Stevens picked up the napkin and the Ving card and compared them. "Incredible!" he breathed softly. "I wouldn't have thought that this was possible!"

Sherlock shrugged modestly. "Unless I'm mistaken, this is how the Phantom has been able to access the off-limits areas of the *Endeavor II*!"

Chapter 12 – The Phantom

The chess tournament was to start fifteen minutes after supper, but I excused myself from the table and hurried to the stateroom that I shared with Lisa. I was thinking of how Sherlock had rescued the two pilots trapped in the doomed minisub simply by being familiar with the operations manual and knowing what to do when the emergency situation arose. I was also thinking of what he had said when I had discovered him working in the library to memorize the New Testament. "God's Word is important," he had told me. "It's our manual for life."

I thought about my own lack of desire for God's Word. Here I was with God's manual for life in my possession, but I wasn't even reading it regularly. What if I had an emergency, and I wasn't even familiar with The Manual?

I slipped my Ving card into the lock, hurried into our room, and fell to my knees beside the bunk. "Lord, forgive me

for being so busy that I didn't have time for You or Your Word," I prayed. "Forgive me for not reading daily. Sherlock has showed me the importance of knowing The Manual. Lord, I know I can't memorize like he does, but help me to be faithful to memorize regularly."

I rose from my knees and went to The Manual. I have no idea how long I read, but the Book of Acts seemed more alive and interesting that night than it had ever been before. After reading three or four chapters, I spent some more time in prayer. It was a special, special time with God that night. Finally, I rose from my knees, placed my Bible on the shelf beside the picnic jug that had saved my life, and then hurried upstairs.

When I got back to the dining saloon, the chess tournament was already in progress. Sherlock was engaged in a battle with one of the scientists, a biologist whom I had seen smoking on the foredeck on several occasions. The man looked like he was in the middle of nicotine withdrawal; his hands shook every time he moved a piece. Within fifteen minutes Sherlock was the winner of his division!

I congratulated Sherlock on his success as he walked to the roster to record his win. He smiled modestly. "No great accomplishment."

"But you just started!" I pointed out. "Most of these people have been playing for years!"

He grinned. "I learn quickly."

The other three games were still going strong, but within minutes, Lieutenant Owens had taken the win in his division. He posted his win on the roster and then strolled over to our table. "I hear that you have a photographic memory," he said, addressing Sherlock. "Is that true?"

Sherlock shrugged. "Yes, sir."

"Have you ever played memory chess?" the officer asked.

My friend shook his head. "I'm not familiar with it."

"The rules are the same," Owens told him, "but the players never see the board. A third party follows the action on an actual board to double-check the players' accuracy, of course, but the players compete with a blank board in front of them. They have to keep track of all the pieces by memory, and if an incorrect move is made, the game is forfeited

automatically. Otherwise, the game is won or lost in the normal fashion.”

Sherlock was intrigued. “Awesome! I’d love to try it.”

Owens plopped down a chessboard. “There’s no time like the present! Do you accept the challenge?”

Sherlock stared at the officer for a moment, and a funny look appeared on his face. “Against you, sir? You’re on.”

Owens turned to me. “Penny, isn’t it? Penny, how about getting one of the free chessboards and tracking the game for us?”

I nodded. “Sure! This sounds like fun!” I found a chessboard already set up and brought it over to a counter that was eighteen inches higher than the table. “I’ll track you from here. I can see your board, but you can’t see this one.”

The officer nodded and smiled at me. “That’s perfect, Penny.” He looked at Sherlock. “Your move.”

Sherlock leaned forward and touched the empty chessboard. “Pawn, forward two.” I moved the appropriate pawn forward on my board.

As the unusual chess game got underway, a ring of spectators began to form around the table. Within minutes, the

two tournament games still in progress were abandoned by the onlookers in favor of the “memory chess” game. To my absolute amazement, both Sherlock and Lieutenant Owens were able to follow the movement of all the pieces without the slightest trouble. I would have lost track after two or three moves, to say nothing of keeping track of the other player’s pieces.

The spectators were impressed. “Incredible! Awesome! Unbelievable!”

It *was* extraordinary. Imagine having the brains to not only carry on a game of chess, but keep track of where all the pieces were without seeing the board! I’ve seen Sherlock do some pretty incredible things—after all, he is a genius with a photographic memory—but this was the absolute topper. It was the most incredible display of brain power that I have ever seen.

But Sherlock played as if his mind was focused on something else. He had no problem whatsoever in remembering where the various pieces were, but I noticed a huge difference in the way he developed his strategies. I’ve

been around Sherlock enough to know when he's preoccupied, and tonight was one of those times.

On the other side of the blank chessboard, Lieutenant Owens was playing a brilliant game. He blazed his way across the board, capturing piece after piece of Sherlock's, always keeping Sherlock on the defensive. Within fifteen minutes he had Sherlock in check.

Sherlock took a full five minutes to make his next move, but it was successful, and the game continued. Ten minutes later, Owens had him in check again. I studied the chessboard in front of me, the one with the actual pieces. I was learning a little about chess this week, but I didn't see any way out. The lieutenant had him.

But Sherlock escaped again, and the game went on. By now it was obvious that the crowd was pulling for Sherlock. They groaned every time he got into trouble, and sighed with relief when he managed to escape.

Finally, the tall lieutenant touched the empty chessboard. "Knight. Check."

Sherlock studied the empty board for three or four long minutes. The crowd waited breathlessly. Some of them came

over and scrutinized my board to search for the right move. Sherlock stood to his feet. "Check mate. Good game, Lieutenant."

The crowd gave both players a hearty round of applause. "Good game, Sherlock," Lieutenant Owens said with a swagger. "It's not often I meet a player with the mental equipment to handle 'memory chess.'" He slipped from the dining saloon.

Sherlock had a strange look on his face as he pulled me into the library just moments later. He closed the door, glanced around to ascertain that the library was empty, then turned back to me. His eyes sparkled with excitement. "We found him!" he exclaimed.

I was completely in the dark. "Found who?"

"The Phantom! We identified the Phantom!"

I stared at him. "We did? Who?"

"Lieutenant Owens!"

I was sure that Sherlock had finally flipped his lid. Maybe the mental strain of the "memory chess" game was too much for him. "Sherlock, you're crazy! He's an Army lieutenant! Why would he be the saboteur?"

“Lieutenant Owens is not an Army officer at all.”

Now I knew that he had lost it. “Sherlock, that’s the most ridiculous thing I ever heard! What makes you think that?”

“Keep your voice down,” he hissed at me.

I glanced at the door and lowered my voice. “Sorry. But why on earth do you think that Lieutenant Owens is the Phantom?”

“I’ll explain it all later,” he told me. “Right now the important thing is to tell Captain Stevens and have Owens arrested.”

I shook my head. “I still think it’s that Iranian dude. I know that you and Lisa and Mr. Diamond think that he’s just a figment of my imagination, but he’s not. I saw him on this ship!”

“It all fits together now,” Sherlock replied, as if he hadn’t even heard me. “Let’s slip up to the 04 level and find the captain.”

My heart was pounding with excitement as we slipped into the stairwell and hurried up the stairs. What Sherlock had just said didn’t make sense, but I have to admit—he’s seldom

wrong. Maybe we had caught the Phantom! Well—not actually caught him yet. But at least we had figured out who he was. It was going to be up to the adults to catch him. Sherlock and I had learned our lesson in that regard.

But as we reached the 02 deck, the stairwell door swung open. Facing us was a very angry lieutenant with a wicked-looking automatic in his right hand. “Hold it right there!” he snarled, pointing the gun at us. “You two aren’t going anywhere!”

Chapter 13 – Abducted!

Lieutenant Owens held open the door at the top of the stairs and gestured toward it with the gun. “After you.” He laughed at us as we stepped through the doorway onto the 02 deck. “Don’t take it so hard, kids. You meant well. But surely you understand that I can’t let you go running to Captain Stevens.”

He checked to make sure that the deck was clear, and then led us hurriedly to a large storage van on the aft section. Unlatching the door, he shoved us inside and stepped in after us. He said it again. “I can’t have you running to the captain, now, can I?”

“How did you know that we had found out?” Sherlock asked him.

Owens laughed quietly. “I had the library bugged,” he replied. “Evans overheard your little discussion and notified

me.” He pulled a tiny radio transmitter from his pocket and flipped it open like a cellular phone. “Phantom Two, are you there?”

“Right here,” a voice replied from the tiny radio.

“Phantom One here,” Owens said softly. I stared at him in the darkness, hardly able to believe what I was hearing. This guy was so arrogant that he was actually using the name “Phantom” as a handle! I noticed that he was talking in a different voice than he normally used. “Get the portside workboat ready now,” Owens said. “We have a couple of passengers. We’ll meet you there in ninety seconds.”

“Gotcha,” the voice replied. “Ready to launch in ninety seconds.”

“Lower the boat into the water but don’t start the motor until you see us,” Owens instructed. “We can’t take any chances.”

My heart was pounding with fear. “What are you going to do with us?” I asked, trying to keep my voice from trembling.

“That’s not for me to decide,” Owens replied. “We’re simply going to take you for a little ride to another ship to talk with my superiors. Then I guess it’s their call.”

I grabbed his arm. “Don’t do it!” I begged. “Don’t take us. They’ll kill us!”

Owens pulled away. “That’s not my problem, is it?” He looked at his watch, waited a short while, and then checked it again. “OK, let’s go. Just walk side by side, slowly and calmly, as if nothing is wrong. If we pass anybody on deck, just nod and keep walking. If they speak to you, wave, but keep walking. I’ll be one step behind you the whole time. And remember this—if you yell out or do anything to get someone’s attention, I’ll shoot you *and* them! Do you understand?”

Sherlock and I nodded nervously.

Owens opened the door of the storage van and stepped out onto the deck. He glanced around and then motioned for us to come out. “Head for the main deck, port side. But remember what I said.”

I was shaking so badly I could hardly stand up. My knees felt as if they were made of jelly, but my feet and ankles felt like stone. Sherlock and I walked slowly toward the stairs

just forward of the storage van. “Sorry, Penny,” Sherlock said softly. “I’m afraid I got you into another mess.”

“Don’t worry about it,” I said, trying to sound unconcerned. “But you know that this is the second time this week.”

“Shut up,” Owens hissed, so we did.

To my disappointment, we made it down to the main deck without seeing a soul. The sky was cloudy and the night was dark. A light wind was blowing across the deck. The ship rocked gently. When we reached the port rail, a dark-haired figure with a slight build materialized out of the shadows. I was surprised to see that it was one of the ship’s electricians, a man named Link Evans. “The workboat’s ready,” he said in a quiet voice.

I glanced over the rail. A yellow inflatable with a stern-mounted outboard motor rolled gently back and forth in the waves, bumping against the ship from time to time.

“Did anyone see you?” Owens asked.

“Not a soul,” his accomplice replied.

“Then it should be safe for you to stay aboard,” the lieutenant told him. “Make yourself scarce. I’ll handle it from here.” Evans nodded and disappeared into the darkness.

Owens gestured with his gun. “OK, kids, into the boat. Do it quickly.” He looked at Sherlock. “You go first.” A sliver of moon darted from behind the clouds, brightening the surface of the ocean.

Sherlock’s face was white with fear as he climbed over the railing and stepped down into the boat. He sank to his knees in the bottom of the craft and grabbed one of the lines that ran through grommets along the side. Owens pointed the gun at me. “You’re next, Penny.”

“Owens, don’t move an inch!” an authoritative voice said quietly. “Raise your hands slowly over your head!” Caught completely off guard, the lieutenant looked to his left, then slowly raised both hands. The automatic in his right hand was pointed at the stars. “Penny, step forward and take the gun from the lieutenant,” the voice ordered.

I obeyed. My hands trembled as I stepped up behind Lieutenant Owens and took the gun from his grasp. Shakily, I pointed the gun at the deck, surprised at how heavy it was. I

turned around, and to my amazement, found myself face to face with the Iranian, who had his own gun leveled at Lieutenant Owens! I was puzzled. This was the man from the airplane! Was he on our side?

A shadow moved behind the Iranian, and before I could cry out, a flash of steel hit him in the back of the head. He slumped to the deck. Link Evans leaped forward and grabbed the gun from his hand. “Get your gun,” he called softly to Owens, who spun around and seized the weapon from my hands.

“Good work, Evans,” the lieutenant said quietly. “I owe you one.” He leaned over the unconscious form on the deck. “Help me get rid of this fool.” To my horror, Owens and Evans lifted the unconscious Iranian and slid him over the rail into the water in front of the inflatable. His body disappeared without even making a splash. Evans gave Owens the thumbs up sign and was gone.

The gun was pointing at me again. “OK, Penny, into the boat.” My heart was paralyzed with terror, but I obeyed. “Both of you into the bow,” our captor ordered as he climbed over the rail. Sherlock and I scrambled to the front of the boat.

Owens jumped down into the inflatable boat. Keeping the pistol pointed in our direction, he started the outboard motor. Owens twisted the throttle on the little motor, revving it to a higher speed. He let the motor drop back down to a slow idle while he stood to his feet and untied the line securing the inflatable to the rail of the *Endeavor II*.

Owens dropped to a kneeling position and twisted the throttle. The inflatable spun away from the side of the ship and powered its way through the waves. My heart sank as I thought about Owens and Evans throwing the Iranian overboard. I had no idea who the man was, but he seemed determined to stop Lieutenant Owens, and that meant that he was on our side.

The outboard motor growled as it chewed its way through the waves. The little inflatable bounced and pitched. Owens turned and stared at the *Endeavor II* for several seconds, and then, satisfied that our departure had not been observed, turned and grinned at us.

We rode in silence for a moment or two. My heart was pounding with terror. I had no idea where Owens was taking

us but I was pretty sure we wouldn't like the eventual destination. I prayed fervently.

Sherlock was eyeing Owens in a way that made me uneasy. It looked as if Sherlock was trying to decide if he could jump the lieutenant and try to take the gun away from him. I hoped he wouldn't try. Even I was smart enough to realize that any such attempt would end in failure.

But Sherlock stood to his feet. Swaying from side to side with the motion of the little craft, he stepped toward Owens. "Better think this through, Lieutenant," he challenged. "Right now you can be charged with kidnapping. Take it any further, and you'll be charged with murder. Is it really worth that?"

Owens looked annoyed. "Sit down, kid," he snapped.

Sherlock dropped to his knees and crawled past the lieutenant. He sat against the starboard side of the inflatable, right against him. "Think what you're doing!" he shouted, grabbing Owens' shirt and pulling on it. "Think what you're doing!" Owens raised the gun as if he were going to strike Sherlock with it, then simply pulled away. Sherlock grabbed his shirt again. "Please, Lieutenant!" he shouted.

I was puzzled. Why was Sherlock acting this way? I've seen him in dangerous situations before, and he always keeps his cool. But tonight he was acting like a madman. He started rocking back and forth, moaning and howling like a creature in pain. He tugged at Owens' shirt. It was dark and I couldn't see the lieutenant too clearly, but he acted like he didn't quite know how to handle the situation.

Just then a slight noise drew my attention to the port side of the little boat, and I almost let out a scream. A man's hand had appeared, reaching over the side of the inflatable! Alarmed, I rolled to the other side of the boat. The water beside the boat seemed to explode as a man rolled over the side and landed in the bottom of the boat! In a flash he jumped to his feet and leaped to the stern. Grabbing Lieutenant Owens' right wrist with his left hand, he punched Owens in the chin with his right.

One punch was all it took. Owens fell back against the transom of the inflatable, unconscious. The force of the blow had nearly knocked him out of the boat. The other man grabbed him by the collar of his jacket and pulled him forward, laying his inert form in the bottom of the boat. He stuck

Owens' gun in his own belt, turned and throttled the outboard motor down a bit, and then looked at Sherlock. "Thank you, my young friend," he said in a foreign accent. I stared. Our rescuer was the Iranian.

The man handed the tiller of the outboard motor to Sherlock. "You take over," he said. He glanced at the unconscious form on the floor of the inflatable. "I must be ready in case she wakes up, yes?"

Sherlock throttled the motor to a higher speed and turned the inflatable in a wide U-turn. I stared at the inert form of the man who had tried to kidnap us. "Why did he say 'in case *she* wakes up'?" I asked Sherlock.

"Because," Sherlock told me, "Lieutenant Owens is a woman!"

Chapter 14 – The Final Dive

The morning sun reflected off the glistening hull of the *Odyssey* as the little sub pitched and rolled in the three-foot waves. Two divers in black wet suits swam back to the fantail of the ship and climbed aboard. The A-frame crane whined and rose to a vertical position. Sherlock, Lisa and I watched the action from our usual vantage on the 02 deck above the hangar.

I yawned. “We stayed up too late,” I said. “I’m so tired I could sleep all day. It must have been nearly midnight when the helicopter finally came and took Owens and Evans away.”

We watched as the waves closed slowly over the *Odyssey*. “You never told me how you knew that Lieutenant Owens was a woman,” I told Sherlock.

“You were the one who sat across from her at mealtimes,” the young detective replied. “How come you didn’t notice?”

“Notice what?” I asked. “She looked like a skinny, skinny man.”

“Didn’t you ever look at her throat?” he retorted. “Didn’t you notice that she had no Adam’s apple? I noticed that the first day she was aboard the *Endeavor II*. And when she looked at her fingernails, she held her hand out with her fingers up and her palm away from her.”

“So?”

“A man would have looked at his nails with his palm up and his fingers curled nearly closed,” he told me. “And there were all sorts of other clues as well.”

“OK, Brains,” I teased, “if you knew that she was a woman impersonating an army ordnance officer, how come you didn’t figure out that she was the Phantom?”

Sherlock looked embarrassed. “I knew that she was a woman,” he said sheepishly, “but somehow it never occurred to me that she could be the Phantom. I guess I—I guess I just thought that she was trying to prove that she was as tough as

the men or, thought that she could make rank faster if her superiors thought that she was a man, or..." He grinned. "I'm not sure what I was thinking! She seemed efficient as an ordnance officer and I guess I just didn't pay that much attention to her. I wasn't expecting the Phantom to be one of the officers, so my guard was down. I guess I can't win them all."

"So how did you finally figure out that she was the Phantom?" Lisa asked.

"Well, like I told Captain Stevens, the Phantom had to have duplicated the captain's Ving card. When he insisted that the card had never been out of his sight, and that Webster and Andersen had been just as careful with their cards, I figured that the Phantom was a person with an excellent memory who could have duplicated the card without actually having it in his possession."

"Her possession," I corrected. "This super-intelligent person was a female, may I remind you."

"She also was a traitor who was willing to work for a terrorist organization against the United States, and was willing to kill you to keep her secret." I stuck my tongue out at him.

"When she challenged me to the game of 'memory chess,' I knew immediately that she had the ability to duplicate the captain's Ving card from memory, and therefore, she had to be the saboteur who had attempted to disable the *Odyssey*."

"What about Link Evans?" I asked. "Was he impersonating a crewmember?"

Sherlock shook his head. "Evans was simply a disgruntled crewmember who was willing to take a bribe," he explained. "He was to be paid forty thousand dollars for his assistance."

"Lieutenant Owens, or whoever she was, was probably planning to kill him when the assignment was over."

Sherlock nodded. "Probably."

"But how did she get assigned to this ship?" Lisa asked. "She wasn't really an Army ordnance specialist."

"No, in reality she was an enemy agent working for an international terrorist organization," Sherlock replied.

"Someone in her organization intercepted the real Lieutenant Terry Owens' orders, cancelled them, and sent her in his place. Her assignment was to keep the *Odyssey* from recovering the missing bomb."

“Which we’re going to do today,” I added.

“Hopefully,” Sherlock replied. He looked at his watch.

“Let’s go down to the communications room and see what’s happening down below the waves.”

I glanced down to the main deck to see our Iranian rescuer standing beside the telescopic boom crane. “There’s the Iranian,” I told Sherlock. “Who is he, anyway? In all the excitement last night, I forgot to ask.”

“His name is Raju Divakar,” Sherlock answered, “and he’s not Iranian; he’s from India.”

“Raju is the head of security at Daddy’s computer company,” Lisa informed me. “He’s an expert in martial arts, weapons, and self-defense, and he serves as a bodyguard whenever Daddy makes an overseas trip.”

“Bodyguard?” I echoed. “Then why didn’t he sit with us on the plane? And why wasn’t he on the helicopter with us?”

“When Raju travels with Daddy, he keeps some distance between them so that most people never realize that they’re together. He watches for danger situations and intervenes when necessary. There was one time in Europe

when he saved Daddy from being kidnapped by some foreign computer interests.”

“But he didn’t come on the helicopter with us,” I pointed out. “And how come we never saw him in the dining saloon?”

“He had some business to take care of for Daddy in Barcelona, so he came later,” Lisa explained. “And he prefers Indian food to ours, so he fixed his own meals in his stateroom. He figured that if as few people as possible knew he was aboard, the better it would be.” She laughed. “Penny, when you kept talking about this ‘Iranian’ guy, we had no idea that you were talking about Raju! He’s not Iranian.”

“Well, he looks Iranian to me,” I countered. I glanced at the man down below, but the place where he had stood just moments before was now empty. “Look, Raju is gone,” I told Sherlock and Lisa.

Just then the Indian bodyguard hurried across the 02 deck toward us. “Greetings, Miss Diamond,” he said to Lisa. “Introduce me to your friends, please.”

As the introductions were made, I shook the man's hand. "Thank you for saving our lives last night," I said softly. "I thought they had killed you."

He smiled shyly, and to my surprise, seemed embarrassed. "Thank the Lord I was able to help," he replied modestly. "When Owens and Evans put me over the rail, the cold water must have revived me, and I found myself floating in the water just in front of the inflatable. I knew that I had to find a way to stop the lieutenant from taking you, so I hung on to the underside of the boat and worked my way along the side. Your friend Sherlock saw me and created a diversion, enabling me to enter the boat and subdue her."

I turned to Sherlock. "So that's what that was all about! For a moment last night, I thought you had gone crazy!"

Sherlock grinned. "I figured that Owens, or whatever her real name is, was trained to handle any situation that came along. I had to create a diversion for Raju, and it had to be something that would completely distract Owens. I just tried for something bizarre and unusual."

"Believe me, it was both," I told him.

Raju shook hands with all three of us. "Thank the Lord He got us safely through last night," he said softly. "It has been a pleasure to meet you, but I must go. I am on an errand for Mr. Diamond." With these words, he hurried across the deck.

"Sharp guy," Sherlock commented. "I like him. And he certainly was in the right place at the right time last night."

"Wait a minute," I said. "If Raju knew that Owens was a woman, how come he didn't notify Mr. Diamond or somebody?"

"He just found out last night," Sherlock replied, "when he tangled with her in the boat." He pointed downward. "Let's head for the communications room, shall we?"

Ninety seconds later we hurried into the communications room. Perkins looked up as we entered. "Good news," he told us. "The *Odyssey* located the bomb again and managed to secure the lifting harness around it! They're on their way to the surface right now to get a tow cable and take it down. The starboard boom crane should be able to retrieve the bomb within a few hours."

It was just about an hour before sunset when Lisa, Sherlock and I slipped into the communications room again to check the progress of the recovery operation. Perkins greeted us at the door. “If you kids hurry, you can watch them bring up the missing bomb,” he told us. “They’ll have it up on deck in about five minutes.”

“Thanks!” Sherlock told him. “We wouldn’t miss this for anything!”

Perkins grinned. “If it hadn’t been for you, Sherlock, the *Odyssey* would still be on the bottom of the ocean. Two good men would have died, and the mission would have ended in failure.”

The young detective shrugged. “God just used me to save their lives.”

My heart was pounding as we left the communications room and hurried up to the main deck. As we stepped out on the open deck we could hear the whine of machinery. We could see that the starboard crane extended out over the water, and was winching in a thick tow cable. But as we hurried aft to watch, Major Powell stepped in front of us. “Sorry, kids, but

nobody’s allowed on deck right now. For the next half hour, this is a restricted area.”

“But we just wanted to watch,” I protested. “We’ll stay out of the way!”

The major crossed his arms over his chest. “Sorry. Nobody is allowed aft right now. You’ll have to go below, or go up to the library or something. Find something else to do.” I looked past him and saw that the deck was empty except for Colonel Andersen and Lieutenant Holloway. Apparently, they weren’t even allowing the ship’s personnel to watch the retrieval of the bomb.

“Can’t we just watch from here?” I argued.

Major Powell was growing impatient. “You heard me,” he growled. “This entire deck is off limits for the present! Find somewhere else to play!”

Sherlock tugged at my arm. “Come on, Penny.”

Disappointed that we weren’t going to be allowed to watch and upset at the way we were being treated, I allowed Sherlock to pull me away. *Why do they treat us like little kids?* I thought angrily. *‘Find somewhere else to play.’ Who do they*

think we are—kindergartners? They wouldn't even be retrieving the bomb if it hadn't been for Sherlock!

To my surprise, Sherlock didn't seem the least bit upset. "We'll go to the 02 deck and watch from beside the aft control station," he told Lisa and me as we hurried forward. "That way we won't be in the way, but we'll still be able to observe the entire operation." He opened the door leading to the stairwell and we scooted up two flights of stairs.

Walking quickly so we wouldn't miss out on anything, we hurried aft. To our dismay, Major Smith and Lieutenant Thompson were standing guard by the aft control station. "Sorry, kids, this area is off limits right now," Major Smith told us. "You'll have to go somewhere else for the next half hour or so."

Foiled again, we headed forward to the stairs. Sherlock paused on the top step. "There's a workboat on the 03 level, starboard side," he told us in a conspiratorial tone of voice. "Why don't you two meet me up there?"

"What are you planning to do?" I asked. He had that strange look in his eyes again, the look that usually meant that we were headed for trouble.

"No time to explain," he said hurriedly. "Just meet me there." He turned and rushed down the stairs with his thin legs going as fast as they could go.

Lisa and I looked at each other and shrugged. "Well," I said with a laugh, "I guess we go up to the 03 deck, huh?"

Moments later we knelt just forward of the inflatable workboat that Sherlock had mentioned. The little craft was suspended just above the deck, hanging from davits that could extend out over the side of the ship and lower the boat to the water below. "Try not to look conspicuous," I whispered to Lisa.

"Right," she shot back. "And just how are we supposed to do that?"

Sherlock came dashing from the forward stairwell moments later and ran to where we crouched, glancing about as if to make certain that we wouldn't be spotted. He was carrying his backpack. "Did anyone see you?" he asked in a whisper, dropping to his knees beside us.

Lisa shrugged. "Not that we know of."

"Good!" Sherlock unzipped the backpack and pulled out a pair of binoculars. He dropped to his belly and scooted

underneath the workboat, and then lifted the binoculars to his eyes. He turned the little focus knob. “We can see the starboard crane from here,” he said, with a note of satisfaction. “Fantastic!” Lisa and I scooted in beside him.

“We made it just in time,” Sherlock observed, peering at the water below. “They’re bringing the bomb up now!”

I leaned forward. Down below us, the crane was still humming and whining. At that moment, the surface of the water on the starboard side of the *Endeavor II* foamed white as a cylindrical object slowly broke the surface and then dipped beneath the water again. An order was shouted, and the crane whined to a stop. The silver-colored cylinder, about half the size of a fifty-five gallon drum, bobbed just below the surface. As we watched, two divers swam out from the ship and attached additional lines to the object.

“Safety lines,” Sherlock told us. “They’re not taking a chance on losing the bomb.”

The crane whined again, and the silvery object slowly lifted from the water. Sherlock studied it through the binoculars. “That’s not a bomb!” he exclaimed. “No way!” He thrust the binoculars at me. “Here!”

I took the binoculars from him. He seized his backpack and unzipped it, trembling with excitement as he pulled out a camera with a telephoto lens. “That’s not a nuclear bomb, Penny!”

I looked through the binoculars and finally found the silver cylinder. The crane was lifting it slowly from the water. “Looks like a bomb to me!” I remarked.

“Have you ever seen a nuclear bomb?” he asked.

“Well, no,” I admitted. “But it has that nuclear symbol on the side of it. You know, that three-sided thing that looks like a ceiling fan with three blades.” I studied the mystery object. “It has a bunch of numbers stenciled on the side, and it has...hey, it looks almost like Chinese writing!”

“What do you think it is, Sherlock?” Lisa asked.

I lowered the binoculars and realized that Sherlock was busily snapping pictures. “I’m not positive,” he answered slowly, continuing to click away with the camera, “but if it’s what I think it is, our national security is being jeopardized!” Still clutching the camera, he backed out from under the workboat and crept to the stern of the little craft, and then rose up on one knee and stealthily snapped several more pictures.

By now the crane had lifted the bomb, or whatever it was, clear of the water and swung it over the afterdeck. The cables whined as they lowered their burden safely to the deck and placed it on a sturdy-looking cart. Two of the military officers immediately rushed over and covered it with a big tarp. As they pushed the whole contraption toward the *Odyssey's* hangar, Sherlock was briskly snapping photos until the edge of the 02 deck hid them from view.

He crawled back under the inflatable workboat, thrust the camera into his backpack, and grabbed the binoculars from me. "Let's get out of here," he whispered, shoving the binoculars in after the camera. "I need to get this film to Mr. Diamond."

At that moment we heard a loud roar overhead and looked up to see a large military helicopter dropping toward the stern of the *Endeavor II*. As we watched, the craft hovered over the afterdeck, and a cable dropped from its belly. Moments later, the cable winched a canvas-shrouded object into the helicopter. I knew what that was.

When the object was safely aboard the helicopter, the thundering craft moved forward and dropped to a hover just

above the helipad. To my surprise, the five Air Force officers appeared on the 02 deck, duffel bags in hand, and hurried up the steps to the helipad. In no time at all, the helicopter was lifting free of the ship, taking the officers with it. "They didn't waste any time getting out of here, did they?" Sherlock remarked.

My heart was in my throat as we scrambled from our hiding place and hurried down the stairs toward the main deck. To my immense relief, we made it safely back to the computer lab where Mr. Diamond was running a final test on the computer system he had installed. He looked up in bewilderment as we tumbled into the room, huffing and puffing. "What's up?" he asked with a grin. "You act as if you're being chased by a band of headhunters!"

"Sir, I need to talk with you," Sherlock stated, breathing hard as he tried to catch his breath. "Do you know anybody with enough authority to call for an investigation at the Pentagon? Do you have any connections in the United States Senate, or maybe in the House? Unless I'm mistaken, our national security is being jeopardized!"

Mr. Diamond started to laugh and then paused as he realized that Sherlock was dead serious. “What are you talking about, Son? What makes you think...”

“Do you, sir? Do you know any high-level government officials that could call for an investigation at the Pentagon? Somebody that you could trust?”

Mr. Diamond frowned. “I’m on pretty good terms with Senator Mike Barrington,” he answered slowly. “He’s a Christian, and of course, a conservative who can be trusted. But what is going on? What are you talking about?”

“Sir, it looks as if someone is selling our nuclear technology to Red China!”

Lisa’s dad let out a low whistle. “That’s a pretty serious charge, Sherlock. Do you realize the political implications for Senator Barrington if he called for an investigation and it turned out that there was nothing to it? I’m afraid that the senator would want to have some pretty conclusive evidence before he stuck his neck out on a charge like this.”

Sherlock withdrew his camera from his backpack. “I have the evidence right here!”

Mr. Diamond looked at him strangely. “What are you talking about?”

“Just a few minutes ago they recovered the missing bomb,” Sherlock replied. “A helicopter just took it and the five Air Force officers off the *Endeavor II*. I got photos of the entire operation. There was just one catch—it wasn’t a bomb at all!”

“How do you know that?”

“The item they winched up from the ocean floor was not a nuclear bomb,” Sherlock insisted. “I’ll have to do some checking, but I believe that the item they recovered was actually a shielded canister of nuclear fuel, plutonium perhaps. Somehow it was lost at sea while it was en route to China.”

“What makes you think it was en route to China?” Mr. Diamond asked. “If the canister did contain a restricted material, the sale of such to China would indeed be a violation of national security.”

“Penny found an encoded fax that Colonel Andersen had dropped,” the boy detective answered. “She showed it to me before she gave it back to the colonel. I memorized it and broke the code.”

“What was in it?” Mr. Diamond asked.

“It was from some official at the Pentagon,” Sherlock replied, “requesting a report on the mission’s progress and stressing the continued need for secrecy. What caught my attention was the mention of the possibility that the mission’s failure could jeopardize certain trade arrangements with Beijing.”

Lisa’s dad frowned. “It actually said that?”

Sherlock nodded.

“But you don’t have the hardcopy of the fax, do you?”

“Penny gave it back to the colonel,” Sherlock explained, “but I memorized it word for word. I can reproduce it verbatim.”

Mr. Diamond smiled. “No doubt you can.” He sighed. “There are a number of liberal politicians pushing for friendlier diplomatic relations and increased trade with Red China, despite the fact that the Chinese government has a long record of brutality and cruelty to its own people. Some international experts are saying that the Chinese Christians are suffering more persecution now than ever before, but many Americans want to overlook this for the sake of doing business with

Beijing. One of our senators recently attacked a bill that would penalize persecution of Christians. She said that the bill would put religious human rights ahead of other human rights and possibly damage America’s foreign policy interests.”

“So business comes first,” I said, “ahead of suffering people.”

He nodded sadly.

“The Chinese are doing everything they can to obtain special favors in the American market,” Sherlock pointed out, “even to the point of making illegal contributions to the campaigns of certain American politicians. And now it looks as if they’ve found a source that will supply them with our nuclear technology.”

Lisa’s dad was silent for several minutes. “I’ll have the final testing of the computer system completed in less than an hour,” he said finally. “We can fly back to Barcelona first thing in the morning and catch a flight back home. I’ll contact Senator Barrington as soon as we get home.” He held out his hand. “How about giving the film to me, and I’ll give it to Raju for safekeeping?”

Sherlock nodded and unloaded his camera. Mr. Diamond looked each of us in the eye as he pocketed the roll of film. “I’m sure you understand the seriousness of the situation,” he said gravely. “Not a word of this to anybody, understand? If Sherlock’s information is correct, this film could be quite valuable to certain people, and there’s no telling what they would do to get it.”

My heart pounded with fear.

“The chess tournament finishes tonight,” he went on, “and I want all four of us to stay together the entire evening. We won’t take any chances. I’ll alert Raju to the situation so that he can keep a close watch. I’ll also have him make arrangements to fly us out first thing tomorrow.”

Chapter 15 – Home Again

I leaned against the window of the airliner, watching the runway leap up at us. “Spencerville Airport,” I said aloud. “We’re almost home.”

Lisa squeezed my hand. “I’m glad you got to come with Daddy and me,” she said softly, almost as if she didn’t want the adventure to end. “It was a good trip.”

The cabin of the aircraft jarred as the plane touched down, and the engines screamed in reverse thrust, trying to slow our forward momentum. “Thanks for inviting Sherlock and me,” I told her. “I enjoyed it thoroughly—well, except for two things: my midnight swim, and the midnight boat ride with Lieutenant Owens. Neither one of those was much fun!”

She smiled sadly. “I’m just thankful that you weren’t hurt or killed,” she whispered softly. “God was watching over you.”

I looked forward to where Sherlock and Mr. Diamond sat talking and laughing together, and then glanced back to where Raju Divakar sat on the aisle several rows behind us. Noticing my gaze upon him, he winked. I grinned at him and turned back around. Now that I knew who he was, it wasn't at all frightening to have him watching us. I was thankful he had been there to stop Lieutenant Owens when she tried to take Sherlock and me from the *Endeavor II* that one night.

The plane was taxiing toward the tiny Spencerville terminal. "Almost home," I said again. "It will sure be good to see Mom and Dad!"

Lisa leaned close to me. "What do you think about what Sherlock said?" she whispered. "Was that a nuclear bomb, or was it something else, like he insists it was?"

"I don't know what to think," I whispered. "It looked like a bomb to me, but Sherlock usually knows what he's talking about. Raju has the film, and your dad said he's going to try to get Senator Barrington to check into it."

The plane came to complete stop in front of the terminal and the seat belt sign winked off. We unsnapped our

seat belts and stood up. Ten minutes later, Mom met us at the baggage carousel and grabbed me in a fierce bear hug.

"Penny, it's good to have you home," she said. "How was your trip?"

I let out a long sigh. "It was quite an adventure. I'll tell you the whole story on the ride home. Did we get a new car?"

Mom nodded. "The insurance settlement came in, and your father was able to buy a three-year-old Dodge Caravan with fairly low mileage. It's nice; you'll like it."

Lisa, Sherlock and Mr. Diamond stepped over to us. "Hello, Mrs. Gordon," Mr. Diamond greeted Mom. "Glad to have her back?"

Mom smiled and nodded. "Did she behave herself?"

Mr. Diamond looked dead serious as he replied, "Pretty well, except for the time she went swimming without permission, and the time she and Sherlock tried to take an unauthorized boat ride at night."

Mom turned to me with a shocked look on her pretty face. "Penny!"

Mr. Diamond laughed. "I'm teasing Penny, Mrs. Gordon," he said with a grin. "I suppose she'll tell you all

about it.” He glanced over at the baggage carousel. “Here comes our luggage.”

“So that’s the way it happened,” I finished, as the new minivan purred into our driveway. “It was a lot more excitement than I had bargained for!” Mom had listened quietly as I told the whole story of the missing bomb, my being thrown overboard, and how Lieutenant Owens had kidnapped Sherlock and me. I concluded by telling her that Sherlock had won the chess championship, hoping that would take her mind off some of the more serious matters, but it didn’t seem to work.

Mom looked troubled. “Oh, Penny,” she said softly. She bit her lip, and I could tell that she was really upset. “Dad and I wouldn’t have let you go if we had realized that you would be in such danger! You and Sherlock could have been killed!”

“We were in the Lord’s hands the whole time, Mom,” I replied, suddenly realizing that I had to reassure her, or I might not get to go along the next time an adventure came our way. “He kept us safe.”

She reached across and hugged me. “Well, I’m just glad it’s over and you’re back in one piece,” she said. She pushed a button and opened the liftgate in the back of the minivan. “Let’s get your things inside.”

It’s not really over, I told myself, until we find out if that thing really was a bomb or not. What if Sherlock was right? I wondered if Mr. Diamond would be able to persuade Senator Barrington to investigate the matter.

During the next few weeks, the beautiful fall weather was replaced by the chilly temperatures of the coming winter. December came in like an angry old woman, howling and moaning and slamming things around. I was thankful that I no longer had to wait at the bus stop each morning for the school bus.

Cold gusts of wind blew little bits of trash down Third Street one afternoon as Dad and I stepped from the car and hurried down the sidewalk toward Willoughby Drug Store to pick up a prescription for Mom. I shoved my hands deep into the pockets of my windbreaker, wishing that I had worn a

warmer jacket, or that Dad had been able to find a parking meter closer to the store. It sure was getting chilly!

It had been just over a month since Sherlock, Lisa and I had taken the voyage with Mr. Diamond. We had been home schooling most of that time, and it was going well. I was thankful to be out of Spencerville Junior High. My thoughts went back to the unfinished mystery of the *Endeavor II* and the *Odyssey*. We never had found out what was in the object that the *Endeavor II*'s crane had pulled from the waters of the North Atlantic. Was it a nuclear bomb? Or was Sherlock correct in thinking that it was something else?

I had asked Sherlock about it on several occasions, but his answers had been vague and disappointing. Apparently, he had made a mistake and was having a hard time admitting it. Modest as he was, a mistake like that could still be a blow to whatever pride he did possess.

"Look at that, Penny!" Dad exclaimed, interrupting my thoughts and pointing to a newspaper machine just outside the drugstore.

I glanced at the little window displaying a copy of the *Willoughby Gazette* and did a double take. Sherlock's picture

was on the front page! The headline screamed, "LOCAL STUDENT STOPS SALE OF NUCLEAR WEAPONS"! I dropped to my knees in amazement, trying to read the article through the little window.

Dad grabbed my arm and lifted me to my feet. "We'll buy a paper, Penny," he said with a chuckle. Dropping some coins into the coin slot, he opened the front of the machine and pulled out a newspaper.

Mom's prescription was forgotten as Dad started reading aloud, "A Senate investigation triggered by a local Junior High student uncovered an illegal plan to sell weapons-grade plutonium-239 to Red China, Pentagon officials revealed today. In a late morning report that shocked the nation's top security advisers, the Pentagon disclosed details of the findings from the investigation conducted by Senator Mike Barrington's office.

"Senator Barrington reports that he first became aware of the international incident when he was given photos taken by a local home schooled student, twelve-year-old Jasper Jones. Jones, known locally as 'Sherlock', had taken the pictures while on a scientific cruise off the coast of Portugal.

The photos, supposedly of an operation to recover a nuclear bomb lost at sea during a refueling mishap, turned out instead to be of a shielded canister of restricted plutonium-239, a discrepancy that was brought to light by Jones himself.

“Reports alleging that the restricted nuclear materials were to be surrendered to the Red Chinese in return for illegal campaign contributions remain to be investigated. Senator Barrington has declared that he will not rest until the allegations are either verified or disproved. Pentagon officials, embarrassed by the incident, are saying...”

Dad stopped reading and looked at me. “Isn’t that something?” He laughed. “Penny, your friend is incredible!” He stepped on the little rubber mat that opens the automatic door to the drugstore. “Let’s get inside where it’s warmer.”

Once we were inside the store, he handed me the newspaper. “Here. You can read the rest while I get your mother’s prescription.”

I spread the paper on top of a self-service photocopier by the door and read the rest of the article. To my immense disappointment, it didn’t even mention me. *I helped, too, I thought bitterly, but Sherlock gets all the recognition.*

As soon as I got home I called Sherlock on the walkie-talkie. “Sherlock here,” he answered almost immediately. “That you, Penny? Over.”

“Sherlock, why didn’t you tell me?” I demanded. I was so excited that I forgot to say “Over.”

“Tell you what, Penny? Over.”

“Why didn’t you tell me that Senator Barrington had done an investigation? I just read about it in the paper! They had a picture of you on the front page! Over.”

“Oh, that. Over.” He was so casual about it that it was infuriating.

“Sherlock, don’t you realize what you did? The newspaper gave you credit for discovering what was going on, and said that Senator Barrington’s investigation came in time to stop any further shipments of nuclear materials to China! You’re a hero, Pal!”

To my surprise, that didn’t seem to matter to him. “I’m thankful that the Lord used us, Penny. Over.”

“The newspaper article said that the canister of plutonium was dropped overboard while being transferred to a

Chinese ship off the coast of Portugal,” I told him. “How did it happen? Over.”

“The plutonium was taken from the Savannah River nuclear storage facility down in Georgia,” he told me. “The transfer was authorized by a certain Army colonel at the Pentagon, shipped aboard a Navy destroyer to some point in the Mediterranean, and flown by Air Force helicopter to the Chinese ship waiting off the coast of Portugal.”

“Sounds like all the branches of the military wanted to have a part,” I interrupted.

“Anyway, the helicopter was hovering over the Chinese ship, winching the canister of plutonium down to the deck when a fitting broke and the canister dropped free. It fell to the deck and bounced into the ocean. Over.”

“So why didn’t they just get some more plutonium?” I asked. “Wouldn’t that haven been easier to keep secret—you know—less chance of being found out? Over.” Holding the walkie-talkie carefully, I flopped down across my bed.

“The Chinese were really upset at the Americans when the accident happened,” Sherlock told me. “I think the Americans decided to retrieve the canister just to save face and

show that we could do it. And, of course, retrieving it would keep some other country from getting their hands on the plutonium. Over.”

“You told me one time that a nuclear bomb would have some kind of a tracking device on it,” I said. “A transponder, or... what did you call it? Over.”

“A location transponder,” he replied.

“Well, wouldn’t a canister of plutonium-239 have the same thing? Why couldn’t they have located it that way? Over.”

“Good thinking,” Sherlock replied, “and you’re right. There was just one problem—the boys at the Pentagon had chosen to have the transponder disabled before they shipped the plutonium, not knowing, of course, that the canister was going to end up on the bottom of the ocean.”

“Hey, now that we’re finally talking about it, I have one more question. Who was Lieutenant Owens? Why was she so interested in stopping us from finding the plutonium? Didn’t she want it to get to China?”

“It hasn’t been proven, but we believe that she was hired by a hostile nation that wanted to recover the plutonium

themselves,” Sherlock replied. “If she could delay the recovery operation long enough so that the United States would give up on it, the interests employing her could move in and attempt to recover it. Over.”

“What will happen to the people at the Pentagon who were responsible for sending the plutonium to China? Will they be arrested? Will they lose their jobs? Over.”

Sherlock sighed. “It wasn’t just the Pentagon bigwigs who were involved in this scheme,” he told me. “There were some high level politicians planning to use the monies to finance their re-election campaigns. Senator Barrington is uncovering all sorts of corruption, but the news media are doing their best to slander him, instead of reporting the truth to the American people. Over.”

“What will happen to those politicians? Over.”

Sherlock snorted. “Probably nothing. It’s as if the American people no longer care about right or wrong. If the economy is good and things are going fairly well, the average citizen doesn’t seem to care about the corruption. On top of that, the liberal media seem to be doing everything they can to

cover for the politicians involved. America’s in trouble, Penny. We need to pray daily for her. Over.”

“Well, anyway, congratulations on your part in stopping the illegal sales,” I told him. “I’m proud to be your friend. Over.”

“And I’m proud to be yours, Penny. Hey, I’ve got to get back to my memorizing. Talk to you later. Over and out.”

“Over and out,” I replied. I pulled my Bible from the shelf beside my bed and dropped to my knees to pray for my country.

